

Pump series IML

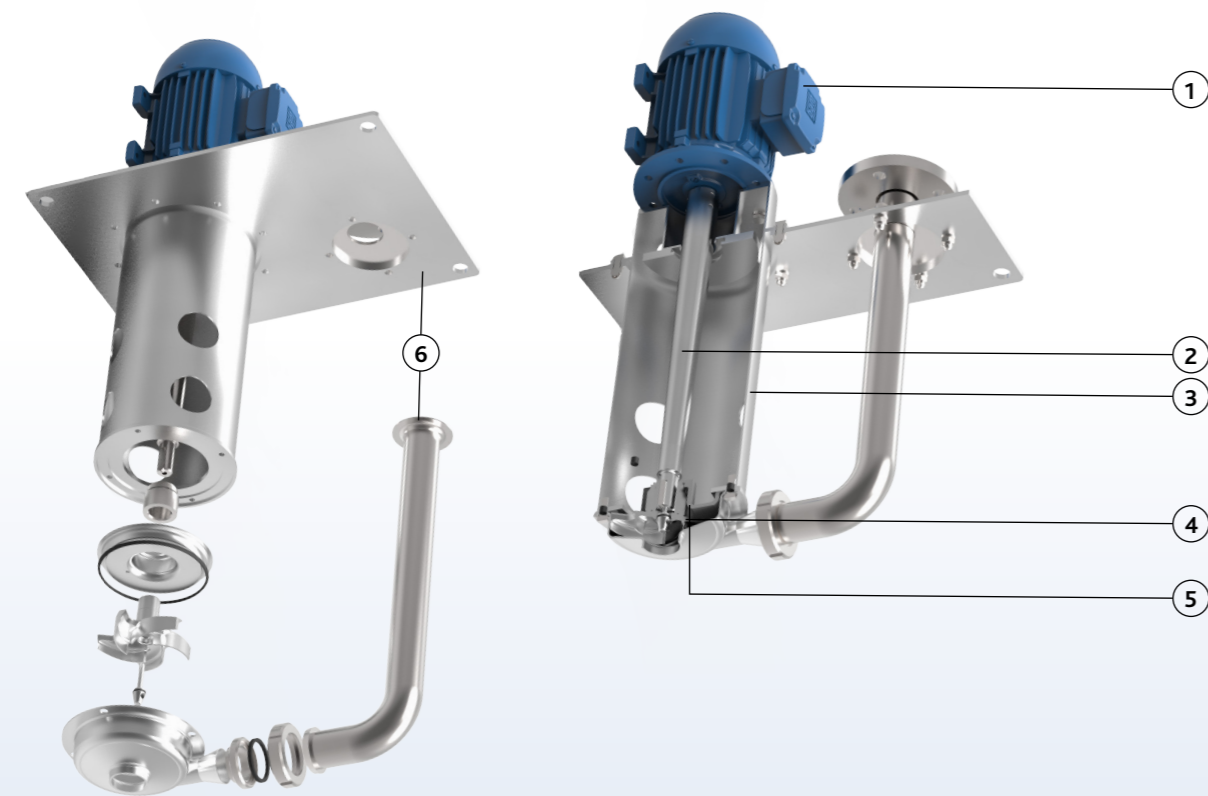

Characteristics

The Packo submersible cantilever pump series IML are designed for installation in a sump or tank, having only the casing and impeller submerged. Because the absence of a mechanical seal and slide bearing in contact with the liquid, the cantilever pumps are maintenance friendly and reduce the downtime. These robust pumps have stainless steel 316L pressed or investment cast pump casings and can be equipped with open, semi-open, closed and vortex impellers. Thanks to its solid construction and electropolished design these pumps are the reliable component for your production process. Available in NP, ICP, MCP, IFF and MFF version with open, semi-open, closed or vortex impellers.



IML

- 1 Use of standard IEC motors
- 2 Tapered shaft, fully machined
- 3 High strength column support pipe. Rigidly maintains alignment between motor and casing. Protects pump shaft.
- 4 Cantilever design = no mechanical seals, no plain bearings. Reduced downtime and operating costs. No bottom bearing, no oil or water pipes required to lubricate these bearings.
- 5 Renewable "labyrinth" shaft sleeve to minimize blow-back of liquid around the shaft. Additional shaft protection against abrasive liquids.
- 6 Optional: stainless steel base plate and outlet pipe

Your benefits

- Cantilever design = leakage free, no seals and plain bearings
- Sealless pump: reducing downtime and operating costs
- Not sensitive for dry running
- Easy construction
- Electropolished: higher resistance against corrosion and sticky liquids
- Robust design
- Available with different impellers





Application areas

They are used in applications for liquids which are difficult to seal with a mechanical seal.

The Packo submersible cantilever pump series IML are used in a wide range of industries and applications such as metal finishing industry, industrial spray washers, water treatment, galvanizing and coating industry, chemical industry, etc.

They are handling degreasing, pickling & phosphatizing liquids, slurries, hot oils, process and industrial wastes, corrosive liquids, condensate, etc.

Pump series

Pump series	IML
Performance	
max. flow rate	1000 m ³ /h
max. differential head	60 m
max. pump length	500 mm
max. liquid viscosity	1000 cP
max. temperature	200°C
impeller type	open, semi-open, closed or vortex
max. free passage	45 mm
max. motor power	132 kW
max. speed	3000 rpm
available frequency	50 / 60 Hz
Technical specifications	
materials wetted parts	stainless steel 316L or similar
mechanical seal configuration	no seal - cantilever
available O-ring materials	EPDM, FKM
connections	hygienic fittings, BSP fittings, flanges according to EN1092-1/01 & 02, ANSI flanges
surface finish	industrial, welds not hand polished, electropolished
certificates & legislation	   

Performance curves

IML

