

Operation

VERDERAIR VA-EH50

Electric-Operated Diaphragm

Pump



859.0769
Rev.A
EN

2-Inch pumps with electric drive for fluid transfer applications.
Not approved for use in explosive atmospheres or hazardous locations unless otherwise stated. See Approvals page for more information. For professional use only.



Important Safety Instructions

Read all warnings and instructions in this manual and in your Repair/Parts manual. **Save these instructions.**

Maximum Working Pressure: 7 bar (0.7 MPa, 100 psi)

See page 8 for approvals.

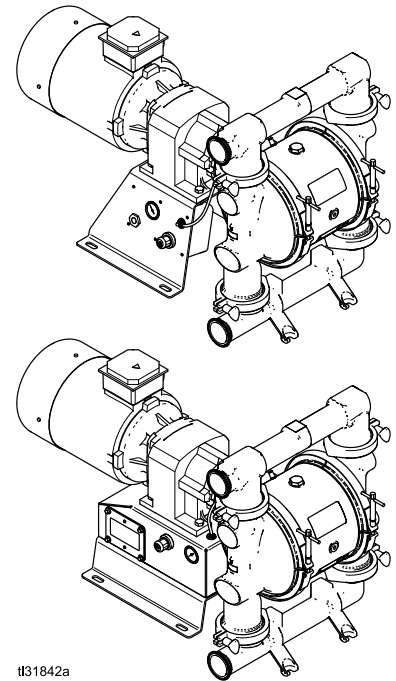

1131842a



Contents









Related Manuals	2	Operation.....	18
Warnings	3	Sanitize the Pump Before First Use.....	18
Pump Matrix.....	6	Transfer Mode Vs. Low Pulsation	
Installation.....	9	Mode	18
General Information	9	Start and Adjust the Pump.....	18
Tighten Clamps Before First Use	9	Pressure Relief Procedure.....	19
Tips to Reduce Cavitation.....	9	Pump Shutdown	19
Mount the Pump	12	Maintenance	20
Ground The System	13	Maintenance Schedule.....	20
Air Line.....	14	Lubrication.....	20
Fluid Supply Line	14	Tighten Connections	20
Fluid Outlet Line.....	14	Flushing and Storage	20
Electrical Connections.....	15	Performance Charts.....	21
Leak Sensor Wiring.....	16	Dimensions.....	24
Compressor Wiring	17	Technical Data	27





Related Manuals







Manual Number	Title
859.0773	VERDERAIR VA-EH50 Electric-Operated Diaphragm Pump, Repair/Parts

Warnings

The following warnings are for the setup, use, grounding, maintenance, and repair of this equipment. The exclamation point symbol alerts you to a general warning and the hazard symbols refer to procedure-specific risks. When these symbols appear in the body of this manual or on warning labels, refer back to these Warnings. Product-specific hazard symbols and warnings not covered in this section may appear throughout the body of this manual where applicable.

 <h1 style="margin: 0;">WARNING</h1>	
 	<p>ELECTRIC SHOCK HAZARD</p> <p>This equipment must be grounded. Improper grounding, setup, or usage of the system can cause electric shock.</p> <ul style="list-style-type: none"> • Turn off and remove power before disconnecting any cables and before servicing or installing equipment. For cart-mounted models, unplug the power cord. For all other units, disconnect power at the main switch. • Connect only to grounded power source. • All electrical wiring must be done by a qualified electrician and comply with all local codes and regulations. • Wait five minutes for capacitor discharge before opening equipment.
    	<p>FIRE AND EXPLOSION HAZARD</p> <p>Flammable fumes, such as solvent and paint fumes, in work area can ignite or explode. Paint or solvent flowing through the equipment can cause static sparking. To help prevent fire and explosion:</p> <ul style="list-style-type: none"> • Use equipment only in well ventilated area. • Eliminate all ignition sources; such as pilot lights, cigarettes, portable electric lamps, and plastic drop cloths (potential static arc). • Ground all equipment in the work area. See Grounding instructions. • Keep work area free of debris, including solvent, rags and gasoline. • Do not plug or unplug power cords, or turn power or light switches on or off when flammable fumes are present. • Use only grounded hoses. • Stop operation immediately if static sparking occurs or you feel a shock. Do not use equipment until you identify and correct the problem. • Keep a working fire extinguisher in the work area. <p>Static charge may build up on plastic parts during cleaning and could discharge and ignite flammable vapors. To help prevent fire and explosion:</p> <ul style="list-style-type: none"> • Clean plastic parts only in well ventilated area. • Do not clean with a dry cloth. • Do not operate electrostatic guns in equipment work area.

 <h1 style="margin: 0;">WARNING</h1>	
	<p>PRESSURIZED EQUIPMENT HAZARD</p> <p>Fluid from the equipment, leaks, or ruptured components can splash in the eyes or on skin and cause serious injury.</p> <ul style="list-style-type: none"> • Follow the Pressure Relief Procedure when you stop spraying/dispensing and before cleaning, checking, or servicing equipment. • Tighten all fluid connections before operating the equipment. • Check hoses, tubes, and couplings daily. Replace worn or damaged parts immediately.
	<p>EQUIPMENT MISUSE HAZARD</p> <p>Misuse can cause death or serious injury.</p> <ul style="list-style-type: none"> • Do not operate the unit when fatigued or under the influence of drugs or alcohol. • Do not exceed the maximum working pressure or temperature rating of the lowest rated system component. See Technical Data in all equipment manuals. • Use fluids and solvents that are compatible with equipment wetted parts. See Technical Data in all equipment manuals. Read fluid and solvent manufacturer's warnings. For complete information about your material, request Safety Data Sheet (SDS) from distributor or retailer. • Turn off all equipment and follow the Pressure Relief Procedure when equipment is not in use. • Check equipment daily. Repair or replace worn or damaged parts immediately with genuine manufacturer's replacement parts only. • Do not alter or modify equipment. Alterations or modifications may void agency approvals and create safety hazards. • Make sure all equipment is rated and approved for the environment in which you are using it. • Use equipment only for its intended purpose. Call your distributor for information. • Route hoses and cables away from traffic areas, sharp edges, moving parts, and hot surfaces. • Do not kink or over bend hoses or use hoses to pull equipment. • Keep children and animals away from work area. • Comply with all applicable safety regulations.
	<p>PRESSURIZED ALUMINUM PARTS HAZARD</p> <p>Use of fluids that are incompatible with aluminum in pressurized equipment can cause serious chemical reaction and equipment rupture. Failure to follow this warning can result in death, serious injury, or property damage.</p> <ul style="list-style-type: none"> • Do not use 1,1,1-trichloroethane, methylene chloride, other halogenated hydrocarbon solvents or fluids containing such solvents. • Do not use chlorine bleach. • Many other fluids may contain chemicals that can react with aluminum. Contact your material supplier for compatibility.

 <h1 style="margin: 0;">WARNING</h1>	
	<p>THERMAL EXPANSION HAZARD</p> <p>Fluids subjected to heat in confined spaces, including hoses, can create a rapid rise in pressure due to the thermal expansion. Over-pressurization can result in equipment rupture and serious injury.</p> <ul style="list-style-type: none"> Open a valve to relieve the fluid expansion during heating. Replace hoses proactively at regular intervals based on your operating conditions.
	<p>PLASTIC PARTS CLEANING SOLVENT HAZARD</p> <p>Many solvents can degrade plastic parts and cause them to fail, which could cause serious injury or property damage.</p> <ul style="list-style-type: none"> Use only compatible water-based solvents to clean plastic structural or pressure-containing parts. See Technical Data in this and all other equipment instruction manuals. Read fluid and solvent manufacturer's Safety Data Sheet (SDS) and recommendations.
	<p>TOXIC FLUID OR FUMES HAZARD</p> <p>Toxic fluids or fumes can cause serious injury or death if splashed in the eyes or on skin, inhaled, or swallowed.</p> <ul style="list-style-type: none"> Read Safety Data Sheet (SDS) to know the specific hazards of the fluids you are using. Store hazardous fluid in approved containers, and dispose of it according to applicable guidelines.
	<p>BURN HAZARD</p> <p>Equipment surfaces and fluid that's heated can become very hot during operation. To avoid severe burns:</p> <ul style="list-style-type: none"> Do not touch hot fluid or equipment.
	<p>PERSONAL PROTECTIVE EQUIPMENT</p> <p>Wear appropriate protective equipment when in the work area to help prevent serious injury, including eye injury, hearing loss, inhalation of toxic fumes, and burns. This protective equipment includes but is not limited to:</p> <ul style="list-style-type: none"> Protective eyewear, and hearing protection. Respirators, protective clothing, and gloves as recommended by the fluid and solvent manufacturer.

Pump Matrix

Check the identification plate (ID) for the Configuration Number of your pump. Use the following matrix to define the components of your pump.

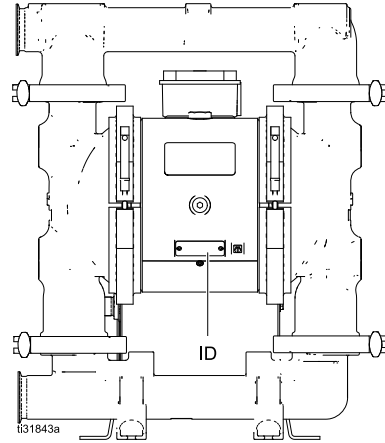

Sample Configuration Number: **VA-EH50 SA ST SP TF T6 AC5K5**







VA-EH50	S	A	ST	SP	TF	T6	AC5K5
Pump Model	Fluid Section Material	Drive Section Material	Check Valve Seats	Check Valve Balls	Diaphragm	Connections	Options

NOTE: Some combinations are not possible. Please check with your local supplier or the pump configurator on www.verderair.com.





Pump	Fluid Section Material		Drive Section Material		Check Valve Seats	
VA-EH50	S	Stainless Steel	A	Aluminum	SE	Stainless Steel with EPDM o-rings
			S	Stainless Steel	ST	Stainless Steel with PTFE o-rings

Balls		Diaphragm		Connections		Options	
NW	Polychloroprene Weighted	SP	Santoprene	D6	Stainless steel, DIN 11851, 65 mm	A15K5	Standard AC Induction Motor (High Speed Gear Ratio) with 120V Air Compressor
SP	Santoprene	TF	PTFE / Polychloroprene 2-Piece	T6	Stainless steel, tri-clamp, 2.5 in.	A25K5	Standard AC Induction Motor (High Speed Gear Ratio) with 220V Air Compressor
TF	PTFE					AC5K5	Standard AC Induction Motor (High Speed Gear Ratio)
						AF5K5	Flameproof AC Induction Motor (High Speed Gear Ratio)
						AX5K5	ATEX AC Induction Motor (High Speed Gear Ratio)
						B14K0	Standard AC Induction Motor (Medium Speed Gear Ratio) with 120V Compressor
						B24K0	Standard AC Induction Motor (Medium Speed Gear Ratio) with 220V Compressor
						BC4K0	Standard AC Induction Motor (Medium Speed Gear Ratio)
						BF4K0	Flameproof AC Induction Motor (Medium Speed Gear Ratio)
						BX4K0	ATEX AC Induction Motor (Medium Speed Gear Ratio)
						C12K2	Standard AC Induction Motor (Low Speed Gear Ratio) with 120V Compressor
						C22K2	Standard AC Induction Motor (Low Speed Gear Ratio) with 220V Compressor
						CC2K2	Standard AC Induction Motor (Low Speed Gear Ratio)
						CF2K2	Flameproof AC Induction Motor (Low Speed Gear Ratio)
						CX2K2	ATEX AC Induction Motor (Low Speed Gear Ratio)
						WG	No Motor, No Gearbox

Pump Matrix

Approvals	
◆ Pumps with motor code X are certified to:	 II 2 G Ex h d IIB T3 Gb
✚ Pumps with motor code WG are certified to:	 II 2 G Ex h IIB T3 Gb
★ Motors coded F are certified to:	 LISTED Class I, Div 1, Group D, T3B Class II, Div 1, Group F & G, T3B 
Ball materials coded TF and diaphragm materials coded TF are certified to:	
All Models (except gearbox and compressor code 1, or motor code F) are certified to:	

Installation

				
<p>Installation of this equipment involves potentially hazardous procedures. Only trained and qualified personnel who have read and who understand the information in this manual should install this equipment.</p> <ul style="list-style-type: none"> All electrical wiring must be done by a qualified electrician and comply with all local codes and regulations 				

General Information

The Typical Installation shown is only a guide for selecting and installing system components. Contact your Verder distributor for assistance in planning a system to suit your needs. Always use Genuine Verder Parts and accessories. Be sure all accessories are adequately sized and pressure rated to meet the system's requirements.

Reference letters in the text, for example (A), refer to the callouts in the figures.

Tighten Clamps Before First Use

After you unpack the pump, and before you use it for the first time, check all clamps and tighten as necessary.

Tips to Reduce Cavitation

Cavitation in a double diaphragm pump is the formation and collapse of bubbles in the pumped liquid. Frequent or excessive cavitation can cause serious damage, including pitting and early wear of fluid chambers, balls, and seats. It may result in reduced efficiency of the pump. Cavitation damage and reduced efficiency both result in increased operating costs.

Cavitation depends on the vapor pressure of the pumped liquid, the system suction pressure, and the velocity pressure. It can be reduced by changing any of these factors.

1. Reduce vapor pressure: Decrease the temperature of the pumped liquid.
2. Increase suction pressure:
 - a. Lower the installed position of the pump relative to the liquid level in the supply.
 - b. Reduce the friction length of the suction piping. Remember that fittings add friction length to the piping. Reduce the number of fittings to reduce the friction length.
 - c. Increase the size of the suction piping.

NOTE: Be sure the inlet fluid pressure does not exceed 25% of the outlet working pressure.
3. Reduce liquid velocity: Slow the cyclic rate of the pump.

Pumped liquid viscosity is also very important but normally is controlled by factors that are process dependent and cannot be changed to reduce cavitation. Viscous liquids are more difficult to pump and more prone to cavitation.

Verder recommends taking all the above factors into account in system design. To maintain pump efficiency, supply only enough power to the pump to achieve the required flow.

Verder distributors can supply site specific suggestions to improve pump performance and reduce operating costs.

Installation

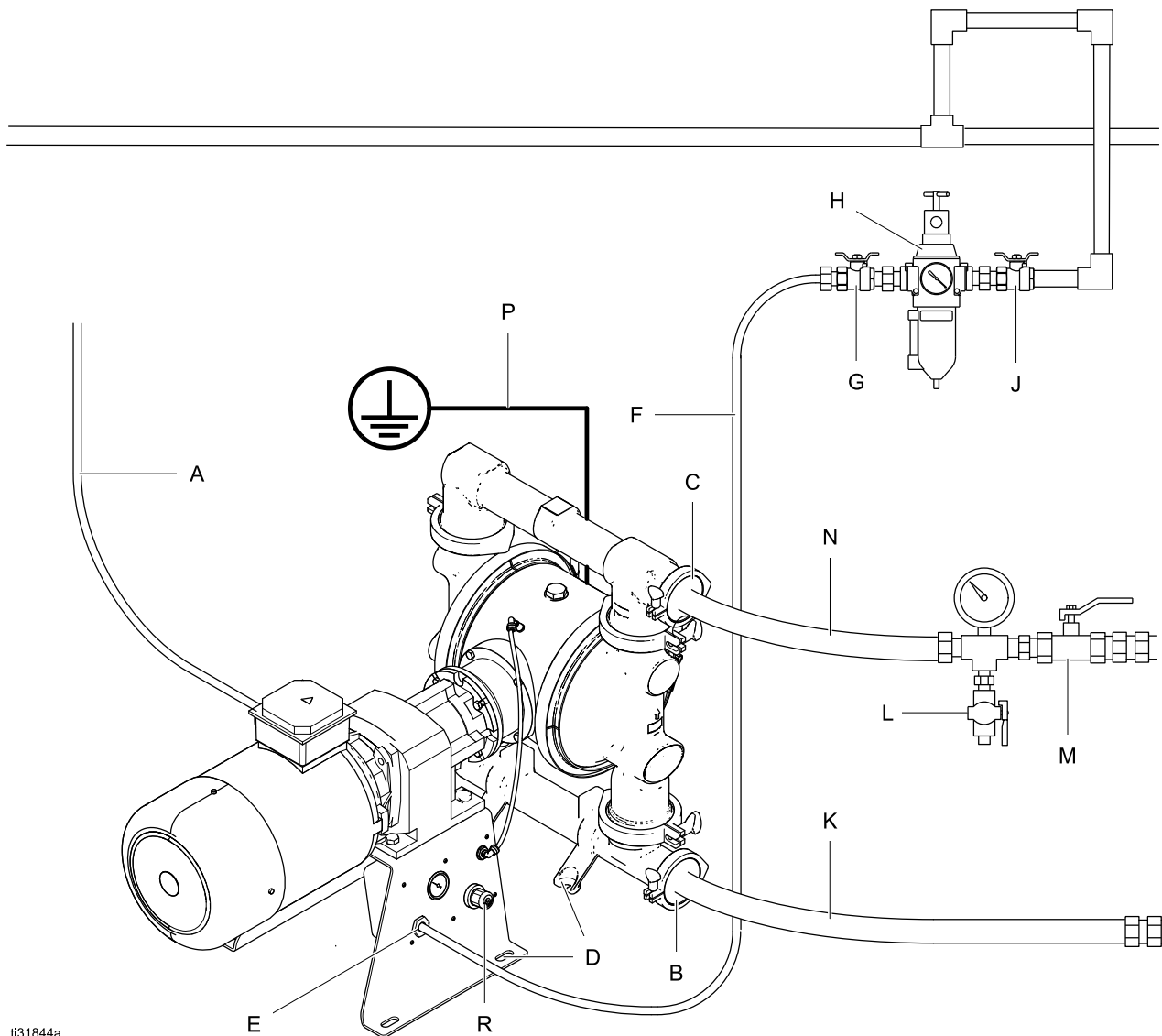

ti31844a

Figure 1 Typical Installation for pumps without a compressor

System Components

B	Fluid inlet port
C	Fluid outlet port
D	Mounting feet
E	Air inlet port
P	Pump Ground
R	Center section regulator

Accessories/Components Not Supplied

A*	Power cord
F*	Grounded, flexible air supply line
G	Bleed-type master air valve
H	Air filter/regulator assembly
J	Master air valve (for accessories)
K*	Grounded, flexible fluid supply line
L	Fluid drain valve (may be required for your pump installation)
M	Fluid shutoff valve
N*	Grounded, flexible fluid outlet line

* Required. Supplied by customer.

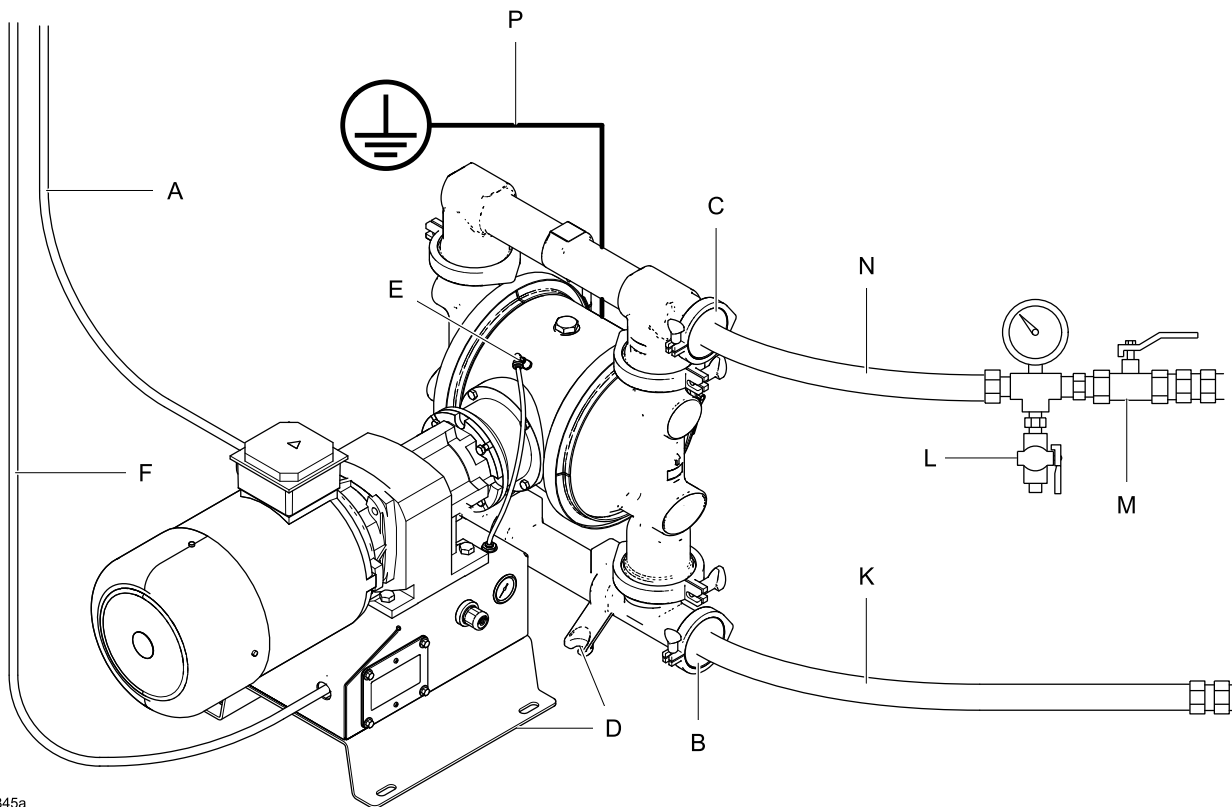

t31845a

Figure 2 Typical installation of a pump with compressor

System Components

- B Fluid inlet port
- C Fluid outlet port
- D Mounting feet
- E Air inlet port
- J Center section regulator
- P Pump Ground

Accessories/Components Not Supplied

- A* Power cord
 - F* Power cord to compressor
 - K* Grounded, flexible fluid supply line
 - L Fluid drain valve (may be required for your pump installation)
 - M Fluid shutoff valve
 - N* Grounded, flexible fluid outlet line
- * Required. Supplied by customer.

Mount the Pump



To avoid serious injury or death from toxic fluid or fumes:

- Never move or lift a pump under pressure. If dropped, the fluid section may rupture. Always follow the [Pressure Relief Procedure, page 19](#), before moving or lifting the pump.

NOTICE

The pump is heavy. To prevent damage from dropping, always use a lift to move the pump. Do not use the manifolds to lift the pump. Use at least two straps.

1. For all mountings, be sure the pump is secured with screws through the mounting feet (D) and through the mounting bracket or compressor box on the gear box. See [Dimensions, page 24](#).

NOTICE

To prevent pump damage, use all eight fasteners.

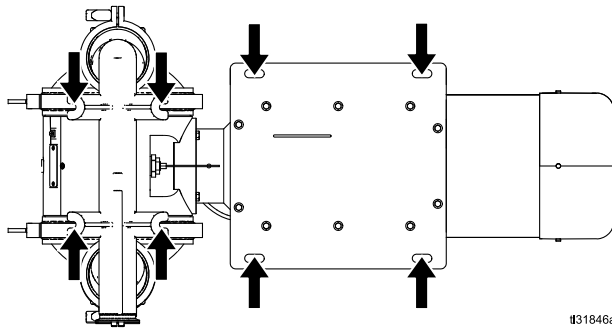

2. Make sure the mounting surface is flat and that the pump doesn't wobble.
3. For ease of operation and service, mount the pump so fluid inlet and fluid outlet ports are easily accessible.

Mounting a pump without a Gearmotor



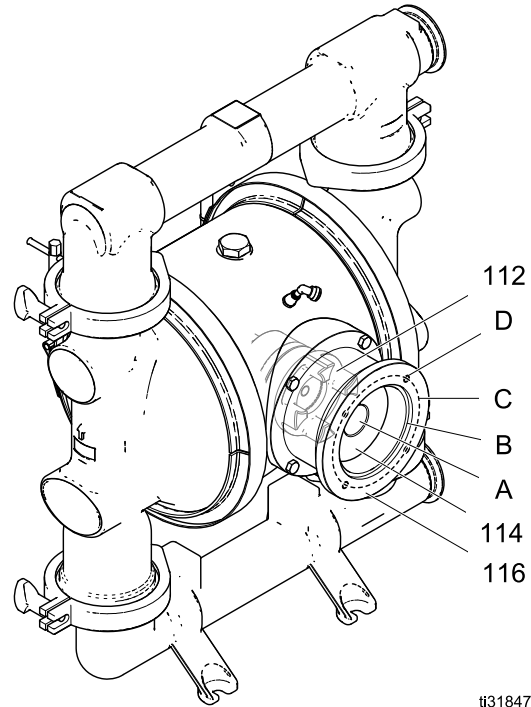

A pump without a Verder gearbox and motor will require a mounting platform to provide support for the customer-supplied motor and gearbox and provide alignment with the pump alignment housing (116) and drive shaft (112) without putting strain on the mounting platform or pump. See [Dimensions, page 24](#) for assistance in fabricating a mounting platform.



REF	DESCRIPTION	DIMENSION
A	Gearbox coupler bore and keyway	35 mm/10 mm keyway
B	Flange pilot diameter	110 mm
C	Bolt circle diameter	130 mm
D	Mounting hole thread size	M8 x 1.25

To specify a non-Verder gearbox, refer to the figure and table above.

Ground The System

				
<p>The equipment must be grounded to reduce the risk of static sparking. Static sparking can cause fumes to ignite or explode. Improper grounding can cause electric shock. Grounding provides an escape wire for the electrical current.</p> <ul style="list-style-type: none"> • Always ground the entire fluid system as described below. • Follow your local fire codes. 				

Before operating the pump, ground the system as explained below.

- **Pump:** All pumps have a ground screw. Loosen the grounding screw. Insert one end of a 4 mm² (12 AWG) minimum ground wire behind the ground screw and tighten the screw securely. Connect the clamp end of the grounding wire to a true earth ground. A ground wire and clamp, Part 819.0157, is available from Verder.

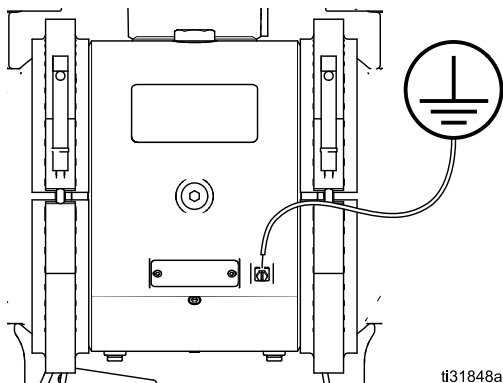

- **Motor:** Motors have a ground screw in the electrical box. Use it to ground the motor to the controller.

- **Air Line and Fluid hoses:** Use only grounded hoses with a maximum of 150 m (500 ft) combined hose length to ensure grounding continuity. Check electrical resistance of hoses. If total resistance to ground exceeds 29 megohms, replace hose immediately.
- **Fluid supply container:** Follow local code.
- **Solvent pails used when flushing:** Follow local code. Use only conductive metal pails, placed on a grounded surface. Do not place the pail on a nonconductive surface, such as paper or cardboard, which interrupts grounding continuity.
- **VFD:** Ground the variable frequency drive (VFD) through a proper connection to a power source. Refer to the VFD manual for grounding instructions.

Check your system electrical continuity after the initial installation, and then set up a regular schedule for checking continuity to be sure proper grounding is maintained. The resistance should not exceed 1 ohm.

Air Line

Models that Include a Compressor:

An air line is already connected from the compressor to the pump air inlet.

Using Your Own Compressor:

Install a grounded, flexible air hose from the compressor to the pump air inlet (E).

Using Shop Air:

1. Install an air filter/regulator assembly (H). The fluid stall pressure will be the same as the setting of the air regulator. The filter removes harmful dirt and moisture from the compressed air supply.
2. Locate a bleed-type master air valve (G) close to the pump and use it to relieve trapped air. Be sure the valve is easily accessible from the pump and located downstream from the regulator.

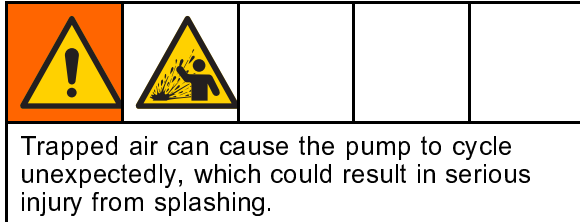

3. Locate another master air valve (J) upstream from all air line accessories and use it to isolate them during cleaning and repair.
4. Install a grounded, flexible air hose (F) between the accessories and the pump air inlet.

Fluid Supply Line

1. Use flexible, grounded fluid hoses.
2. For best sealing results, use a standard tri-clamp or DIN style sanitary gasket of a flexible material such as EPDM, Buna-N, fluoroelastomer, or silicon.
3. If the inlet fluid pressure to the pump is more than 25% of the outlet working pressure, the ball check valves will not close fast enough, resulting in inefficient pump operation. Excessive inlet fluid pressure also will shorten diaphragm life. Approximately 0.21–0.34 bar (3–5 psi, 0.02–0.03 MPa) should be adequate for most materials.
4. For maximum suction lift (wet and dry), see [Technical Data, page 27](#). For best results, always install the pump as close as possible to the material source. Minimize suction requirements to maximize pump performance.

Fluid Outlet Line

1. Use flexible, grounded fluid hoses.
2. For best sealing results, use a standard tri-clamp or DIN style sanitary gasket of a flexible material such as EPDM, Buna-N, fluoroelastomer, or silicon.
3. Install a fluid drain valve (L) near the fluid outlet.
4. Install a shutoff valve (M) in the fluid outlet line.

Electrical Connections



Wire Connections at the Motor (Motor Code 1, 2, C)

NOTE: Follow the instructions in the motor manufacturer's manual. Use a motor starter with overload protection. Wire size, fuse size, and other electrical devices must comply with all local codes and regulations.

The motor must be wired to the VFD. Install the wiring at the motor as follows:

1. Remove 4 bolts to open the motor's electrical box.
2. Install a strain relief in one of the ports at the bottom of the junction box.
3. Connect the green ground wire to the ground screw.
4. **For 230 V motors:** Bridge as shown, then connect L1 to T1, L2 to T2, and L3 to T3.

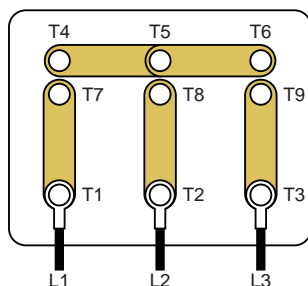

Figure 3 Wire Connections for a 230 V Motor

5. **For 460 V motors:** Bridge as shown, then connect L1 to T1, L2 to T2, and L3 to T3.

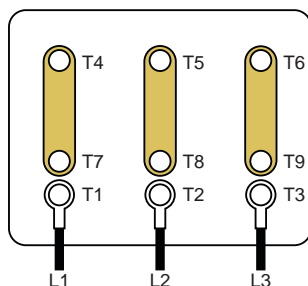

Figure 4 Wire Connections for a 460 V Motor

6. Close the motor electrical box. Torque the bolts to 2.2 N•m (20 in-lb).

Wire Connections at the ATEX Motor (Motor Code X)

Install the wiring at the motor as follows:

1. Open the motor's electrical box.
2. Install wiring system with proper connections to the motor electrical box.
3. Connect the green ground wire to the ground screw.
4. **For 400V Wiring:** Bridge as shown, then connect wire L1 to U1, L2 to V1, and L3 to W1.

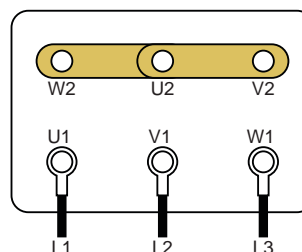

Figure 5 Connections for 400V Wiring

5. **For 230V Wiring:** Connect wire L1 to U1, L2 to V1, and L3 to W1. Bridge as shown.

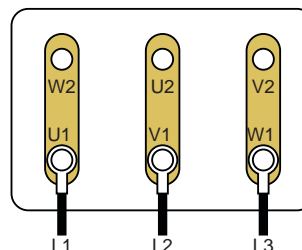

Figure 6 Connections for 230V Wiring

6. Torque terminals to 2.3 N•m (20 in-lb).
7. Close the motor electrical box. Torque the screws to 2.3 N•m (20 in-lb).
8. Connect thermostat wires P1 and P2 to external overload detection. Thermostat is NC (normally closed).

Installation

Wire Connections at the Explosionproof Motor (Motor Code F)

Install the wiring at the motor as follows:

1. Open the motor's electrical box.
2. Install wiring system with proper connections to the motor electrical box.
3. Connect the green ground wire to the ground screw.
4. **For 460V Wiring:** Connect wire L1 to T1, L2 to T2, and L3 to T3, and bridge the other wires, as shown.

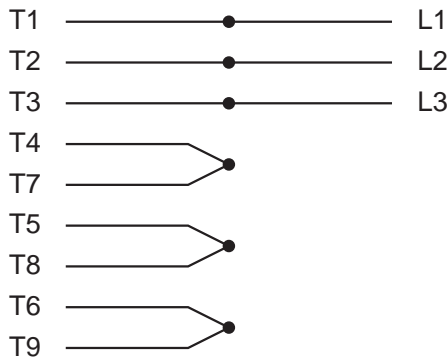

Figure 7 Connections for 460V Wiring

5. **For 230V Wiring:** Bridge the wires as shown. Then, connect L1 to T1/T7, L2 to T2/T8, and L3 to T3/T9.

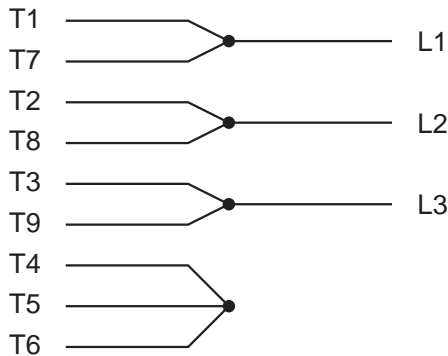

Figure 8 Connections for 230V Wiring

6. Connect thermostat wires P1 and P2 to external overload detection. Thermostat is NC (normally closed).
7. Close the motor electrical box. Torque the screws to 2.3 N•m (20 in-lb).





Leak Sensor Wiring

Follow these instructions to wire the Leak Sensor to a VFD.

NOTE: The leak sensor is designed to operate as a normally-closed circuit.

1. Turn off power to the VFD.
2. Open the access cover on the VFD.
3. For a Verder VFD, perform the following:
 - a. Wire one lead to terminal 4 on the rail.
 - b. Wire a second lead to terminal 13A on the rail.
 - c. Close the access cover.
 - d. Turn on power to the VFD.
 - e. Go to screen P121.
 - f. Change the value to 21 and press the Mode button.
4. For a non-Verder VFD, perform the following:
 - a. Attach the two leads to the detection circuit in the VFD.
NOTE: Refer to the VFD manual for proper connection points.
 - b. Close the access cover.
 - c. Turn on power to the VFD.
 - d. Configure the VFD to monitor the leak sensor circuit.
5. Refer to the VFD manual for information on how to configure the VFD to generate a fault or stop the pump when a leak is detected.

Compressor Wiring

				
<p>To avoid injury from fire, explosion, or electric shock, all electrical wiring must be done by a qualified electrician and comply with all local codes and regulations.</p>				

Follow these instructions to wire Verder Compressor 859.0504 (120V) or 859.0505 (240V).

NOTE: Use only copper wire with an insulation rating of 75°C or higher.

1. Remove the cover from the compressor's electrical box.

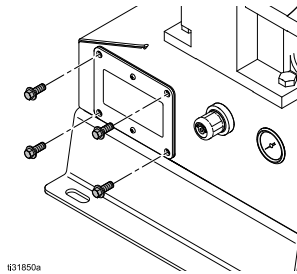

031850a

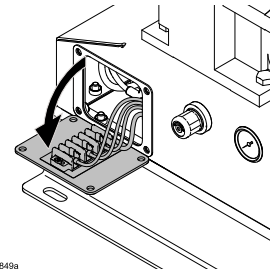

031849a

2. Install wiring system with proper connections (i.e. conduit/fittings, power cable/cable grip) to the compressor electrical box.
3. Connect line power (120VAC or 240 VAC, depending on your compressor) to L1 and L2/N.

Connect supply ground to . Use minimum 4 mm² (12 AWG) wire when the system is configured for a 16A circuit and 2.5 mm² (14 AWG) when configured for a 12A circuit. Torque terminals to 1.2 N•m (10 in-lb).

4. Reinstall the cover of the electrical box. Torque screws to 6.8 N•m (60 in-lb).

Figure 9

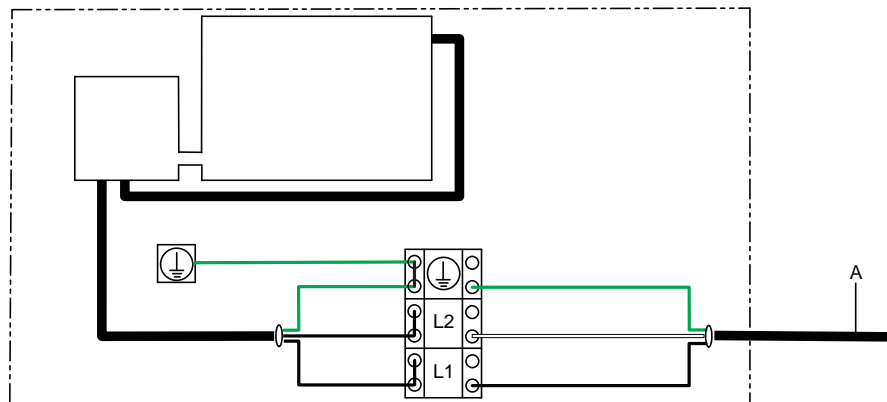

KEY

A To power supply

Operation

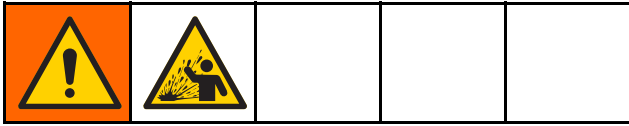

Sanitize the Pump Before First Use

It is the user's responsibility to properly sanitize the pump before first use. It is up to the user whether this will include disassembling and cleaning individual parts or simply flushing pump with a sanitizing solution. As necessary, follow the steps under [Start and Adjust the Pump, page 18](#), or [Flushing and Storage, page 20](#).

Transfer Mode Vs. Low Pulsation Mode

When the air pressure is at least 0.7 bar (10 psi) higher than the desired outlet pressure, the pump is in Transfer Mode and no pulsation damping is occurring. To reduce outlet pulsation, start by setting the air pressure *equal* to the desired outlet fluid pressure. Continue to adjust the air pressure relative to the outlet fluid pressure. Lower relative air pressures produce more pulsation damping. Higher relative air pressures produce better pump efficiency.

Start and Adjust the Pump

1. Be sure the pump is properly grounded. See [Ground The System, page 13](#).
2. Check fittings to be sure they are tight. Use a compatible liquid thread sealant on male threads. Tighten fluid inlet and fluid outlet fittings securely.
3. Place the suction tube (if used) in fluid to be pumped.

NOTE: If fluid inlet pressure to the pump is more than 25% of outlet working pressure, the ball check valves will not close fast enough, resulting in inefficient pump operation.

NOTICE

Excessive fluid inlet pressure can reduce diaphragm life.

4. Place the end of the fluid hose into an appropriate container.
5. Close the fluid drain valve.
6. Turn the air regulator knob to match the desired fluid stall pressure. Open all bleed-type master air valves.
7. If the fluid hose has a dispensing device, hold it open. Be sure all fluid shutoff valves are open.
8. Set the desired frequency on the VFD.
9. Press the start (run) button on the VFD.
10. If you are flushing, run the pump long enough to thoroughly clean the pump and hoses.

Pressure Relief Procedure



Follow the Pressure Relief Procedure whenever you see this symbol.

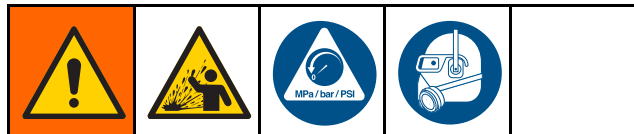

This equipment stays pressurized until pressure is relieved manually. To help prevent serious injury from pressurized fluid, such as splashing in the eyes or on skin, follow the Pressure Relief Procedure when you stop pumping and before you clean, check, or service the equipment.



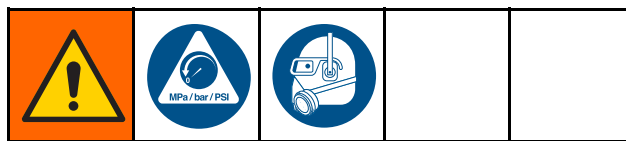

1. Remove power from the system.
2. Open the dispensing valve, if used.
3. Open the fluid drain valve (L), if used, to relieve fluid pressure. Have a container ready to catch the drainage.
4. Shut off the air supply to the pump.
5. Back out center section regulator to relieve air pressure in center section.

Pump Shutdown



At the end of the work shift and before you check, adjust, clean, or repair the system, follow the [Pressure Relief Procedure, page 19](#).

Maintenance

				
<p>To avoid injury from fire, explosion, or electric shock, all electrical wiring must be done by a qualified electrician and comply with all local codes and regulations.</p>				

Maintenance Schedule

Establish a preventive maintenance schedule based on the pump's service history. Scheduled maintenance is especially important to prevent spills or leakage due to diaphragm failure.

Lubrication

The pump is lubricated at the factory. It is designed to require no further lubrication for the life of the bearings. There is no need to add an inline lubricator under normal operating conditions.

Tighten Connections

Before each use, check all hoses for wear or damage and replace as necessary. Check to be sure all connections are tight and leak-free. Check mounting bolts.

Flushing and Storage

				
<p>To avoid injury from fire, explosion, or electric shock, always ground equipment and waste container. To avoid static sparking and injury from splashing, always flush at the lowest possible pressure..</p>				

- Flush before first use.
- Flush at the end of the day, before storing, and before repairing equipment.
- Flush at the lowest pressure possible. Check connectors for leaks and tighten as necessary.
- Flush with a fluid that is compatible with the fluid being dispensed and the equipment wetted parts.
- Always flush the pump and relieve the pressure before storing it for any length of time.

NOTICE

Flush the pump often enough to prevent the fluid you are pumping from drying or freezing in the pump and damaging it. Store the pump at 0°C (32°F) or higher. Exposure to extreme low temperatures may result in damage to plastic parts.

Performance Charts

Test Conditions: The pump was tested in water with the inlet submerged. The air pressure was set at 7 bar (100 psi).

2. Set the VFD frequency corresponding to the desired flow rate. Flow rates will increase with outlet pressure lower than 0.7 bar (10 psi) and with high inlet head pressure.

How to Use the Charts

1. Choose a flow rate and outlet pressure that falls below the Power Limit Curve. Conditions outside of the curve will decrease the life of the pump.

High speed gear ratio pumps with option Ax5K5

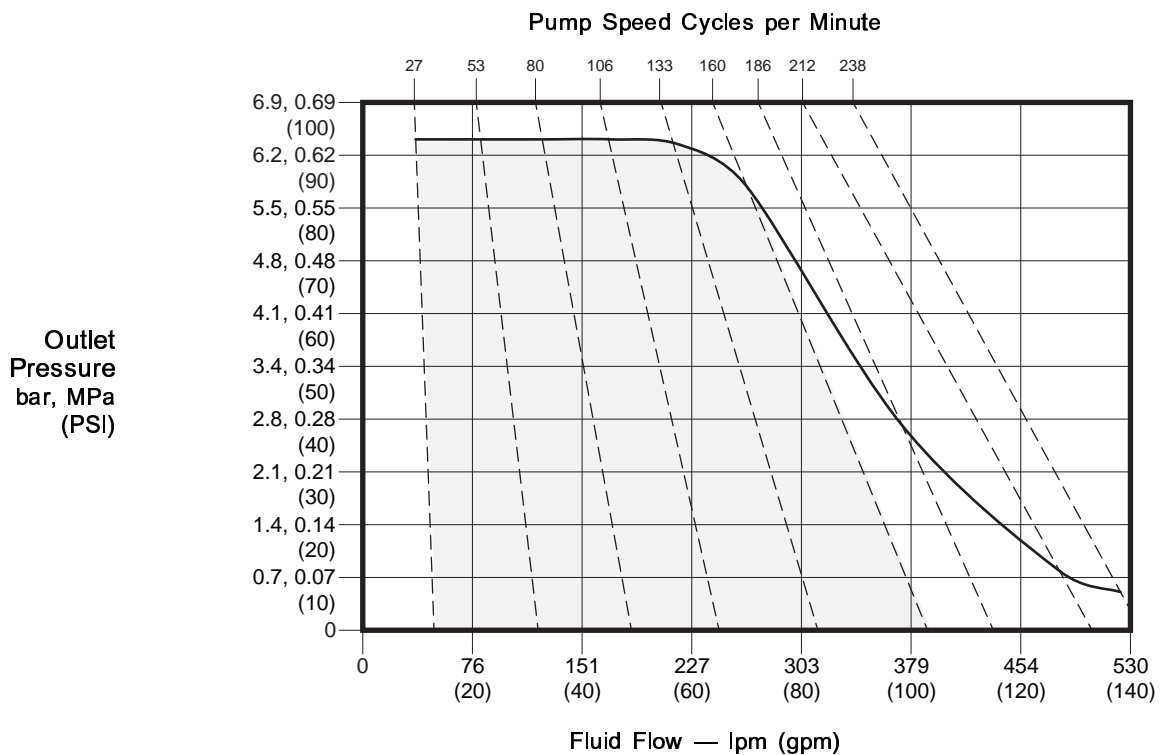

Medium speed gear ratio pumps with option Bx4K0

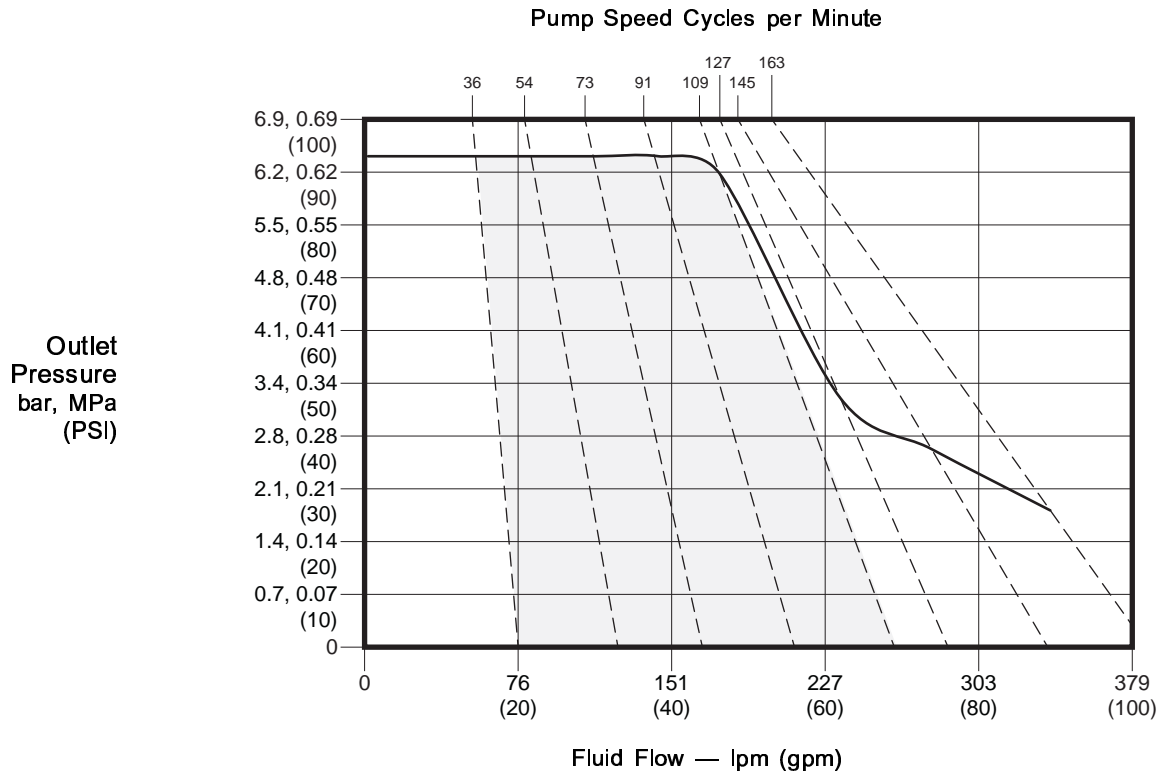

Low speed gear ratio pumps with option Cx2K2

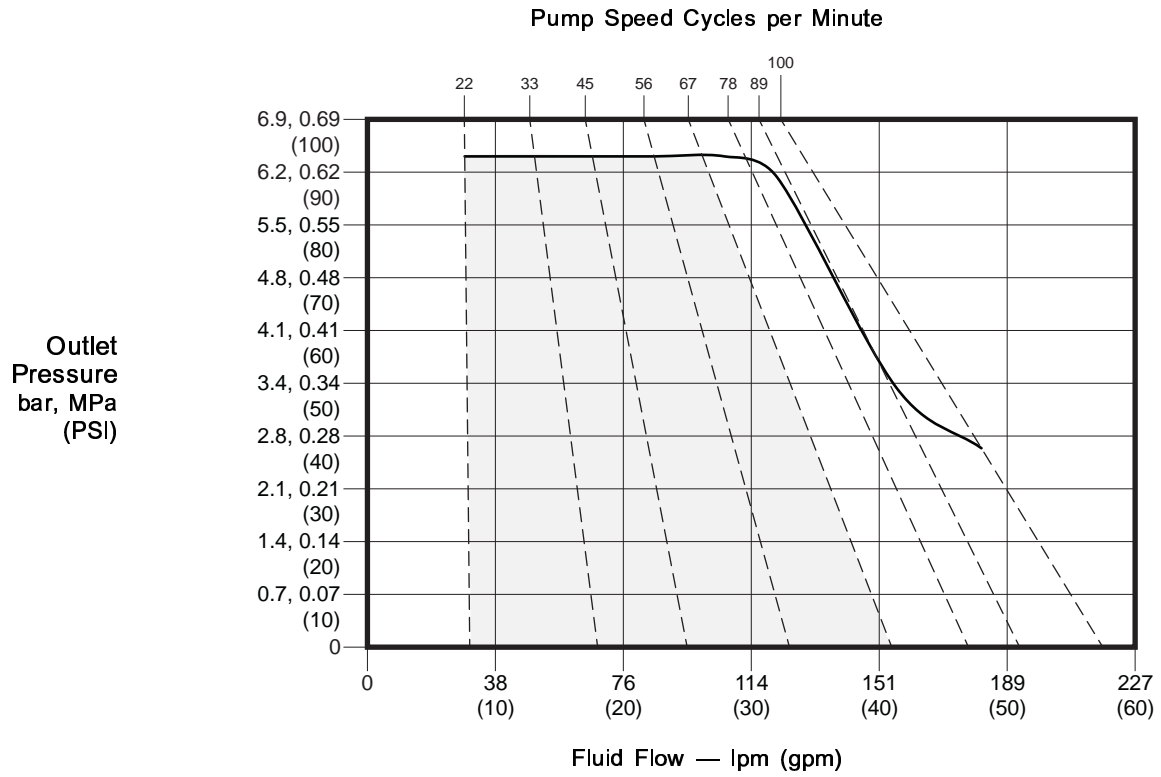

Dimensions

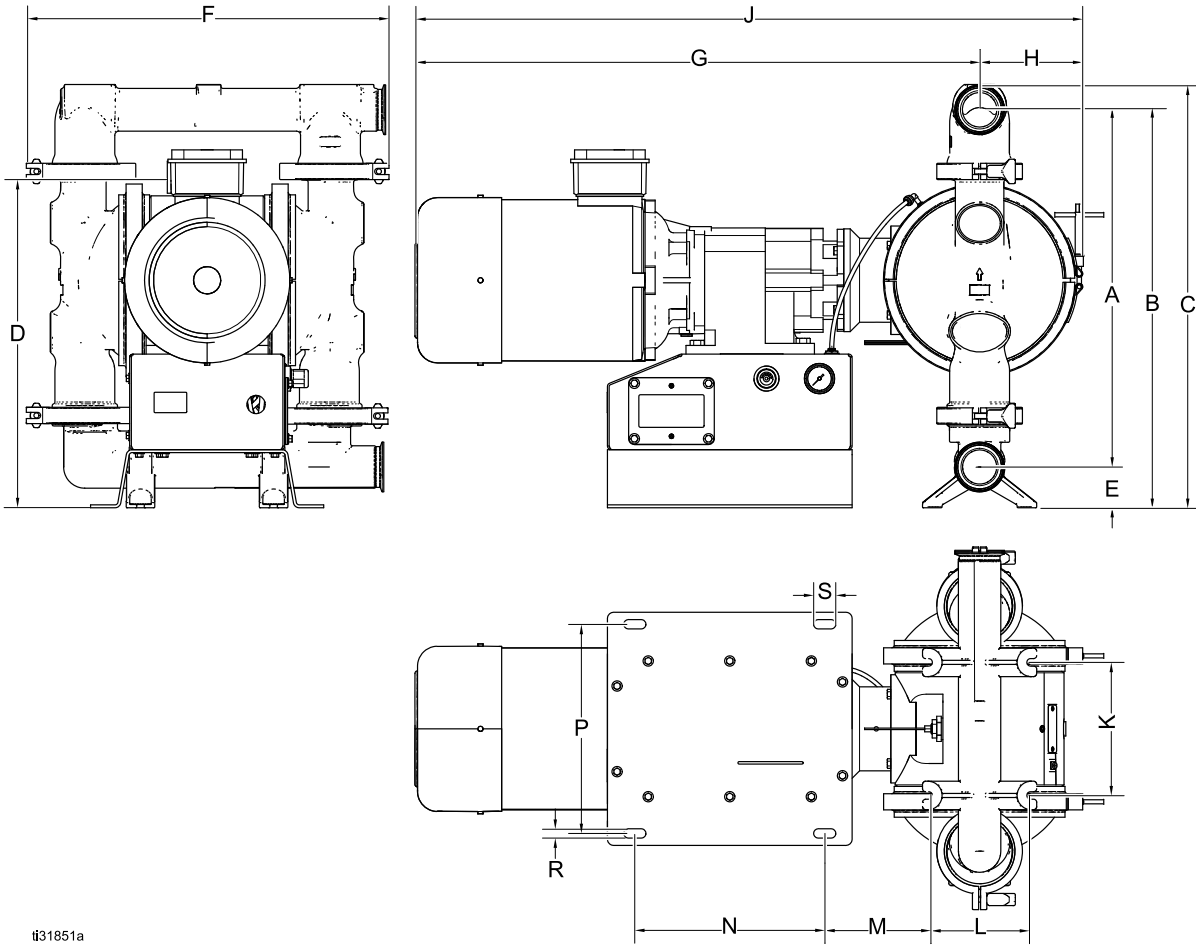

ti31851a

Stainless steel pump with compressor

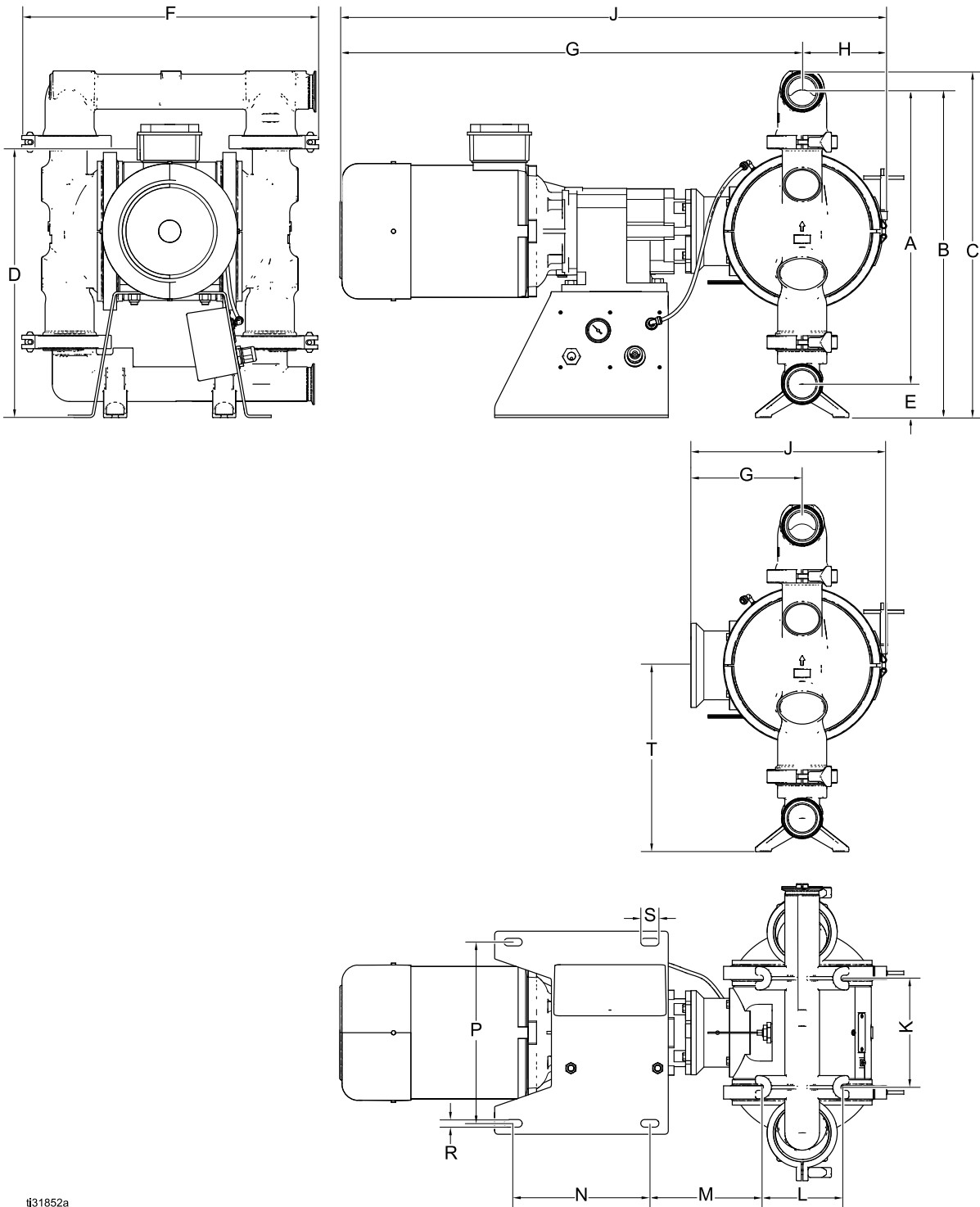

431852a

Stainless steel pump without compressor

Table 1 Dimensions for VERDERAIR Pumps

Ref.	Motor and Gearbox Code – Dimensions shown in cm (inches)													
	WG	AC	A1, A2	BC	B1, B2	CC	C1, C2	AX	BX	CX	AF	BF	CF	
A	55.6 (21.9)	55.6 (21.9)	55.6 (21.9)	55.6 (21.9)	55.6 (21.9)	55.6 (21.9)	55.6 (21.9)	55.6 (21.9)	55.6 (21.9)	55.6 (21.9)	55.6 (21.9)	55.6 (21.9)	55.6 (21.9)	
B	11.2 (24.4)	11.2 (24.4)	11.2 (24.4)	11.2 (24.4)	11.2 (24.4)	11.2 (24.4)	11.2 (24.4)	11.2 (24.4)	11.2 (24.4)	11.2 (24.4)	11.2 (24.4)	11.2 (24.4)	11.2 (24.4)	
C	66.0 (26.0)	66.0 (26.0)	66.0 (26.0)	66.0 (26.0)	66.0 (26.0)	66.0 (26.0)	66.0 (26.0)	66.0 (26.0)	66.0 (26.0)	66.0 (26.0)	66.0 (26.0)	66.0 (26.0)	66.0 (26.0)	
D	---	51.3 (20.2)	51.3 (20.2)	49.3 (19.4)	49.3 (19.4)	48.3 (19.0)	48.3 (19.0)	53.8 (21.2)	51.8 (20.4)	51.8 (20.4)	34.3 (13.5)	35.3 (13.9)	26.4 (10.4)	
E	6.4 (2.5)	6.4 (2.5)	6.4 (2.5)	6.4 (2.5)	6.4 (2.5)	6.4 (2.5)	6.4 (2.5)	6.4 (2.5)	6.4 (2.5)	6.4 (2.5)	6.4 (2.5)	6.4 (2.5)	6.4 (2.5)	
F	55.9 (22.0)	55.9 (22.0)	55.9 (22.0)	55.9 (22.0)	55.9 (22.0)	55.9 (22.0)	55.9 (22.0)	55.9 (22.0)	55.9 (22.0)	55.9 (22.0)	55.9 (22.0)	55.9 (22.0)	55.9 (22.0)	
G	21.1 (8.3)	87.9 (34.6)	87.9 (34.6)	81.8 (32.2)	81.8 (32.2)	77.2 (30.4)	77.2 (30.4)	105.2 (41.4)	88.6 (34.9)	86.1 (33.9)	111.3 (43.8)	95.3 (37.5)	95.0 (37.4)	
H	16.0 (6.3)	16.0 (6.3)	16.0 (6.3)	16.0 (6.3)	16.0 (6.3)	16.0 (6.3)	16.0 (6.3)	16.0 (6.3)	16.0 (6.3)	16.0 (6.3)	16.0 (6.3)	16.0 (6.3)	16.0 (6.3)	
J	37.1 (14.6)	103.9 (40.9)	103.9 (40.9)	97.8 (38.5)	97.8 (38.5)	93.0 (36.6)	93.0 (36.6)	121.2 (47.7)	104.6 (41.2)	102.1 (40.2)	127.3 (50.1)	111.0 (43.7)	111.0 (43.7)	
K	20.8 (8.2)	20.8 (8.2)	20.8 (8.2)	20.8 (8.2)	20.8 (8.2)	20.8 (8.2)	20.8 (8.2)	20.8 (8.2)	20.8 (8.2)	20.8 (8.2)	20.8 (8.2)	20.8 (8.2)	20.8 (8.2)	
L	16.0 (6.3)	16.0 (6.3)	16.0 (6.3)	16.0 (6.3)	16.0 (6.3)	16.0 (6.3)	16.0 (6.3)	16.0 (6.3)	16.0 (6.3)	16.0 (6.3)	16.0 (6.3)	16.0 (6.3)	16.0 (6.3)	
M	---	21.1 (8.3)	16.3 (6.4)	21.1 (8.3)	16.3 (6.4)	21.1 (8.3)	16.3 (6.4)	21.1 (8.3)	21.1 (8.3)	21.1 (8.3)	21.1 (8.3)	21.1 (8.3)	21.1 (8.3)	
N	---	25.9 (10.2)	29.5 (11.6)	25.9 (10.2)	29.5 (11.6)	25.9 (10.2)	29.5 (11.6)	25.9 (10.2)	25.9 (10.2)	25.9 (10.2)	25.9 (10.2)	25.9 (10.2)	25.9 (10.2)	
P	---	34.5 (13.6)	32.5 (12.8)	34.5 (13.6)	32.5 (12.8)	34.5 (13.6)	32.5 (12.8)	32.5 (12.8)	32.5 (12.8)	32.5 (12.8)	32.5 (12.8)	32.5 (12.8)	32.5 (12.8)	
R	---	1.5 (0.6)	1.5 (0.6)	1.5 (0.6)	1.5 (0.6)	1.5 (0.6)	1.5 (0.6)	1.5 (0.6)	1.5 (0.6)	1.5 (0.6)	1.5 (0.6)	1.5 (0.6)	1.5 (0.6)	
S	---	3.6 (1.4)	3.6 (1.4)	3.6 (1.4)	3.6 (1.4)	3.6 (1.4)	3.6 (1.4)	3.6 (1.4)	3.6 (1.4)	3.6 (1.4)	3.6 (1.4)	3.6 (1.4)	3.6 (1.4)	
T	35.3 (13.9)	---	---	---	---	---	---	---	---	---	---	---	---	

Technical Data

Verderair VA-EH50 Electric Double Diaphragm Pump		
	US	Metric
Maximum fluid working pressure	100 psi	0.7 MPa, 7 bar
Air pressure operating range	20 to 100 psi	0.14 to 0.7 MPa, 1.4 to 7 bar
Air inlet size	3/8 in. npt(f)	
Maximum suction lift (reduced if balls don't seat well due to damaged balls or seats, lightweight balls, or extreme speed of cycling)	Wet or Dry: 18 ft	Wet or Dry: 5.5 m
Maximum size pumpable solids	1/4 in.	6.3 mm
Minimum ambient air temperature for operation and storage. NOTE: Exposure to extreme low temperatures may result in damage to plastic parts.	32° F	0° C
Fluid displacement per cycle (free-flow)	0.6 gallons	2.27 liters
Maximum free-flow delivery (continuous duty)	100 gpm	378 lpm
Maximum pump speed (continuous duty)	160 cpm	
Fluid Inlet and Outlet Size		
Stainless Steel	2.5 in sanitary flange or 65 mm DIN 11851	
Electric Motor		
AC, Standard CE (AC5K5 , A15K5 , A25K5)		
Power	7.5 HP	5.5 kW
Number of Motor Poles	4-Pole	
Speed	1800 rpm (60 Hz) or 1500 rpm (50 Hz)	
Constant Torque	6:1	
Gear Ratio	11.25	
Voltage	3-phase 230V / 3-Phase 460V	
Maximum Amperage Load	19.5 A (230V) / 9.75 A (460V)	
IE Rating	IE3	
AC, Standard CE (BC4K0 , B14K0 , B24K0)		
Power	5.0 HP	4.0 kW
Number of Motor Poles	4-Pole	
Speed	1800 rpm (60 Hz) or 1500 rpm (50 Hz)	
Constant Torque	6:1	
Gear Ratio	16.46	
Voltage	3-phase 230V / 3-Phase 460V	
Maximum Amperage Load	13.0 A (230V) / 6.5 A (460V)	
AC, Standard CE (CC2K2 , C12K2 , C22K2)		
Power	3.0 HP	2.2 kW
Number of Motor Poles	4-Pole	
Speed	1800 rpm (60 Hz) or 1500 rpm (50 Hz)	
Constant Torque	6:1	
Gear Ratio	26.77	
Voltage	3-phase 230V / 3-Phase 460V	

Technical Data

Maximum Amperage Load	7.68 A (230V) / 3.84 A (460V)	
IE Rating	IE3	
AC, ATEX (AX5K5)		
Power	7.5 HP	5.5 kW
Number of Motor Poles	4-Pole	
Speed	1800 rpm (60 Hz) or 1500 rpm (50 Hz)	
Constant Torque	6:1	
Gear Ratio	11.88	
Voltage	3-phase 240V / 3-Phase 415V	
Maximum Amperage Load	20 A (230V) / 11.5 A (460V)	
AC, ATEX (BX4K0)		
Power	5.0 HP	4.0 kW
Number of Motor Poles	4-Pole	
Speed	1800 rpm (60 Hz) or 1500 rpm (50 Hz)	
Constant Torque	6:1	
Gear Ratio	16.46	
Voltage	3-phase 240V / 3-Phase 415V	
Maximum Amperage Load	14.7 A (230V) / 8.5 A (460V)	
AC, ATEX (CX2K2)		
Power	3.0 HP	2.2 kW
Number of Motor Poles	4-Pole	
Speed	1800 rpm (60 Hz) or 1500 rpm (50 Hz)	
Constant Torque	6:1	
Gear Ratio	26.77	
Voltage	3-phase 240V / 3-Phase 415V	
Maximum Amperage Load	8.5 A (230V) / 5.0 A (460V)	
AC, Explosionproof (AF5K5)		
Power	7.5 Hp	3.7 kW
Number of Motor Poles	4-Pole	
Speed	1800 rpm (60 Hz) or 1500 rpm (50 Hz)	
Constant Torque	6:1	
Gear Ratio	11.88	
Voltage	3-phase 230V / 3-Phase 460V	
Maximum Amperage Load	20.0 A (230V) / 10.0 A (460V)	
AC, Explosionproof (BF4K0)		
Power	5.0 Hp	4.0 kW
Number of Motor Poles	4-Pole	
Speed	1800 rpm (60 Hz) or 1500 rpm (50 Hz)	
Constant Torque	6:1	
Gear Ratio	16.46	
Voltage	3-phase 230V / 3-Phase 460V	
Maximum Amperage Load	13.0 A (230V) / 6.5 A (460V)	
AC, Explosionproof (CF2K2)		

Power	3.0 Hp	2.2 kW
Number of Motor Poles	4-Pole	
Speed	1800 rpm (60 Hz) or 1500 rpm (50 Hz)	
Constant Torque	6:1	
Gear Ratio	26.77	
Voltage	3-phase 230V / 3-Phase 460V	
Maximum Amperage Load	8 A (230V) / 4 A (460V)	
Leak Sensor		
Contact Ratings:		
State	Normally closed	
Voltage	240V Max (AC/DC)	
Current	0.28 A max at 120 VAC 0.14 A max at 240 VAC 0.28 A max at 24 VDC 0.07 A max at 120 VDC	
Power	30 W max	
Ambient Temperature	-20° to 40°C (-4° to 104°F)	
Ex Ratings:		
Classification: "simple apparatus" in accordance with UL/EN/IEC 60079-11, clause 5.7 Class I, Div 1, Group D, T3B Class II, Div 1, Group F&G, T3B		
		
II 2 G Ex ib IIC T3		
Parameters	$U_i = 24\text{ V}$ $I_i = 280\text{ mA}$ $P_i = 1.3\text{ W}$ $C_i = 2.4\text{ pF}$ $L_i = 1.00\text{ }\mu\text{H}$	
Noise Data		
Sound Power (measured per ISO-9614-2)		
at 90 psi fluid pressure and 80 cpm	84 dBa	
at 60 psi fluid pressure and 160 cpm (full flow)	92 dBa	
Sound Pressure [tested 3.28 ft (1 m) from equipment]		
at 90 psi fluid pressure and 80 cpm	74 dBa	
at 60 psi fluid pressure and 160 cpm (full flow)	82 dBa	
Wetted Parts		
Wetted parts include material(s) chosen for seat, ball, and diaphragm options, plus the pump's material of construction: Stainless Steel		
Non-wetted parts		
Non-wetted parts include aluminum, coated carbon steel, PTFE, stainless steel, polypropylene		

WEIGHTS

Pump Material	Motor/Gearbox																					
	Standard AC*						ATEX AC						Flameproof AC						No Gear-motor			
	AC5K5		BC4K0		CC2K2		AX5K5		BX4K0		CX2K2		AF5K5		BF4K0		CF2K2		WG			
Aluminum	lb	kg	328	149	308	139	475	215	351	159	325	147	517	234	427	194	418	190	217	98		
Stainless Steel	lb	kg	442	200	410	186	390	177	557	253	433	196	407	185	599	271	509	231	500	227	299	136

* For compressor codes 1 or 2, add 13 kg (28 lb).

Fluid Temperature Range

NOTICE

Temperature limits are based on mechanical stress only. Certain chemicals will further limit the fluid temperature range. Stay within the temperature range of the most-restricted wetted component. Operating at a fluid temperature that is too high or too low for the components of your pump may cause equipment damage.

Diaphragm/Ball/Seat Material	Stainless Steel Pump Fluid Temperature Range	
	Fahrenheit	Celsius
Polychloroprene check balls (NW)	0° to 180°F	-18° to 82°C
Santoprene check balls or diaphragm (SP)	-40° to 180°F	-40° to 82°C
PTFE check balls or two-piece PTFE/Polychloroprene diaphragm (TF)	40° to 220°F	4° to 104°C

* The maximum temperature listed is based on the ATEX standard for T4 temperature classification.

Customer Services/Guarantee

CUSTOMER SERVICES

If you require spare parts, please contact your local distributor, providing the following details:

- Pump Model
- Type
- Serial Number, and
- Date of First Order.

GUARANTEE

All VERDER pumps are warranted to the original user against defects in workmanship or materials under normal use (rental use excluded) for two years after purchase date. This warranty does not cover failure of parts or components due to normal wear, damage or failure which in the judgement of VERDER arises from misuse.

Parts determined by VERDER to be defective in material or workmanship will be repaired or replaced.

LIMITATION OF LIABILITY

To the extent allowable under applicable law, VERDER's liability for consequential damages is expressly disclaimed. VERDER's liability in all events is limited and shall not exceed the purchase price.

WARRANTY DISCLAIMER

VERDER has made an effort to illustrate and describe the products in the enclosed brochure accurately; however, such illustrations and descriptions are for the sole purpose of identification and do not express or imply a warranty that the products are merchantable, or fit for a particular purpose, or that the products will necessarily conform to the illustration or descriptions.

PRODUCT SUITABILITY

Many regions, states and localities have codes and regulations governing the sale, construction, installation and/or use of products for certain purposes, which may vary from those in neighboring areas. While VERDER attempts to assure that its products comply with such codes, it cannot guarantee compliance, and cannot be responsible for how the product is installed or used. Before purchasing and using a product, please review the product application as well as the national and local codes and regulations, and be sure that product, installation, and use complies with them.

Original instructions. This manual contains English.

Revision A, February 2018

Austria Verder Austria Eitnergasse 21/Top 8 A-1230 Wien AUSTRIA Tel: +43 1 86 51 074 0 Fax: +43 1 86 51 076 e-mail: office@verder.at	Belgium Verder nv Kontichsesteenweg 17 B-2630 Aartselaar BELGIUM Tel: +32 3 877 11 12 Fax: +32 3 877 05 75 e-mail: info@verder.be	China Verder Shanghai Instruments and Equipment Co., Ltd Building 8 Fuhai Business Park No. 299 Bisheng Road, Zhangjiang Hiteck Park Shanghai 201204 CHINA Tel: +86 21 33932950 Fax: +86 21 33932955 e-mail: info@verder.cn	
Bulgaria Verder Bulgaria Ltd Vitosh department, Manastriski Livadi Zapad district, 110 Bulgaria Blvd., 2-nd Floor, apt. 15-16, 1618 - Sofia BULGARIA Tel: 0878407370 Fax: 02 9584085 email: office@verder.bg	Czech Republic Verder s.r.o. Vodnanská 651/6 (vchod Chlumecka 15) 198 00 Praha 9-Kyje CZECH REPUBLIC Tel: +420 261 225 386-7 Web: http://www.verder.cz e-mail: info@verder.cz	Denmark Verder A/S Sales Denmark Leningradweg 5 NL 9723 TP Groningen THE NETHERLANDS Tel: +45 3636 4600 e-mail: info@verder.dk	France Verder France 8 Allée Rosa Luxembourg Immeulde Arizona 95610 Eragny sur Oise FRANCE Tel: +33 173 43 98 41 Fax: +33 134 64 44 50 e-mail: info@verder.fr
Germany Verder Deutschland GmbH Retsch-Allee 1-5 42781 Haan GERMANY Tel: 02104/2333-200 Fax: 02104/2333-299 e-mail: info@verder.de	Hungary Verder Hungary Kft Budafoke ut 187 - 189 HU-1117 Budapest HUNGARY Tel: 0036 1 3651140 Fax: 0036 1 3725232 e-mail: info@verder.hu	India Verder India Pumps Pvt Ltd. Plot No-3B, D-1 Block, MIDC Chinchwad, Pune - 411019 INDIA e-mail: Sales@verder.co.in www.verder.co.in	Italy Verder Italia Via Maestri Del lavoro, 5 02100 Vazia, Rieti ITALY Tel: +39 07 46 229064 e-mail: info@verder.it
The Netherlands Verder BV Leningradweg 5 NL 9723 TP Groningen THE NETHERLANDS Tel: +31 50 549 59 00 Fax: +31 50 549 59 01 e-mail: info@verder.nl	Poland Verder Polska ul.Porcelanowa 23 PL-40 036 Katowice POLAND Tel: +48 32 78 15 032 Fax: +48 32 78 15 034 e-mail: verder@verder.pl	Romania Verder România Drumul Balta Doamnei no 57-61 Sector 3 CP 72-117 032624 Bucuresti ROMANIA Tel: +40 21 335 45 92 Fax: +40 21 337 33 92 e-mail: office@verder.ro	Slovak Republik Verder Slovakia s.r.o. Silacska 1 SK-831 02 Bratislava SLOVAK REPUBLIK Tel: +421 2 4463 07 88 Fax: +421 2 4445 65 78 e-mail: info@verder.sk
South Africa Verder SA 197 Flaming Rock Avenue Northlands Business Park Newmarket Street ZA Northriding SOUTH AFRICA Tel: +27 11 704 7500 Fax: +27 11 704 7515 e-mail: info@verder.co.za	Switzerland Verder Deutschland GmbH Sales Switzerland Retsch-Allee 1-5 D-42781 Haan GERMANY Tel: +41 (0)61 331 33 13 Fax: +41 (0)61 331 63 22 e-mail: info@verder.ch	United Kingdom Verder UK Ltd. Unit 3 California Drive Castleford, WF10 5QH UNITED KINGDOM Tel: +44 (0) 1924 221 001 Fax: +44 (0) 1132 465 649 e-mail: info@verder.co.uk	United States of America Verder Inc. 312 Corporate Parkway Suite 101 Macon, GA 31210 USA Tel: +1 877 783 7337 Fax: +1 478 476 9867 e-mail: sales@verder-us.com