

Repair/Parts Verder VA-EH25 and VA-E2H25



Electric-Operated Diaphragm

Pumps

859.0531
Rev.L
EN

For fluid transfer in indoor sanitary applications. Not approved for use in explosive atmospheres or hazardous (classified) locations. See approvals page for more information. For professional use only.



Important Safety Instructions

Read all warnings and instructions in this manual and in your Operation manual before using the equipment. **Save these instructions.**

For maximum operating pressures, see the Performance Charts in the Operation manual.

See pages 6 to 11 for model information, including approvals.

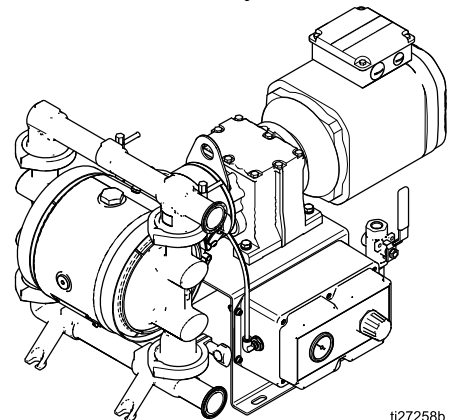
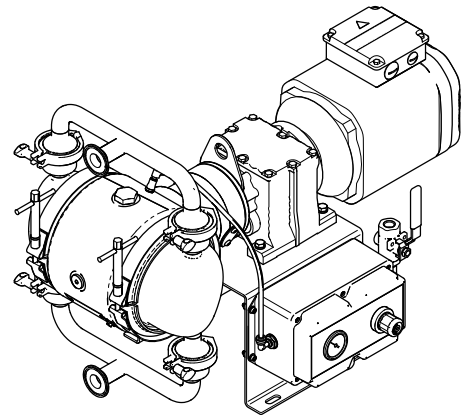

ti27258b



Contents

Related Manuals	2	Pressure Relief Procedure	14
Warnings	3	Check Valve Repair	14
Configuration Number Matrix for VA-EH25 Food Grade Pumps	6	Diaphragm Repair	16
Configuration Number Matrix for VA-E2H25 High Sanitary Pumps	8	Center Section Repair	19
Approvals	10	Replace Center Bearing	22
Overview	11	Replace the Compressor	24
Troubleshooting	12	Parts	25
Repair	14	Kits and Accessories	34
		Technical Data	35
		Customer Services/Guarantee	38







Related Manuals







Manual Number	Title
859.0530	Verder VA-EH25 and VA-E2H25 Electric-Operated Diaphragm Pumps, Operation

Warnings

The following warnings are for the setup, use, grounding, maintenance, and repair of this equipment. The exclamation point symbol alerts you to a general warning and the hazard symbols refer to procedure-specific risks. When these symbols appear in the body of this manual or on warning labels, refer back to these Warnings. Product-specific hazard symbols and warnings not covered in this section may appear throughout the body of this manual where applicable.

 <h1 style="margin: 0;">DANGER</h1>	
 	<p>SEVERE ELECTRIC SHOCK HAZARD</p> <p>This equipment can be powered by more than 240 V. Contact with this voltage will cause death or serious injury.</p> <ul style="list-style-type: none"> Turn off and disconnect power at main switch before disconnecting any cables and before servicing equipment. This equipment must be grounded. Connect only to grounded power source. All electrical wiring must be done by a qualified electrician and comply with all local codes and regulations.
 <h1 style="margin: 0;">WARNING</h1>	
    	<p>FIRE AND EXPLOSION HAZARD</p> <p>Flammable fumes, such as solvent, in work area can ignite or explode. Solvent flowing through the equipment can cause static sparking. To help prevent fire and explosion:</p> <ul style="list-style-type: none"> Use equipment only in well ventilated area. Eliminate all ignition sources; such as pilot lights, cigarettes, portable electric lamps, and plastic drop cloths (potential static sparking). Ground all equipment in the work area. See Grounding instructions. Keep work area free of debris, including solvent, rags and gasoline. Do not plug or unplug power cords, or turn power or light switches on or off when flammable fumes are present. Use only grounded fluid lines. Stop operation immediately if static sparking occurs or you feel a shock. Do not use equipment until you identify and correct the problem. Keep a working fire extinguisher in the work area. <p>Static charge may build up on plastic parts during cleaning and could discharge and ignite flammable vapors. To help prevent fire and explosion:</p> <ul style="list-style-type: none"> Clean plastic parts only in well ventilated area. Do not clean with a dry cloth.

 <h1 style="margin: 0;">WARNING</h1>	
 	<p>PRESSURIZED EQUIPMENT HAZARD</p> <p>Fluid from the equipment, leaks, or ruptured components can splash in the eyes or on skin and cause serious injury.</p> <ul style="list-style-type: none"> • Follow the Pressure Relief Procedure when you stop spraying/dispensing and before cleaning, checking, or servicing equipment. • Tighten all fluid connections before operating the equipment. • Check lines, tubes, and couplings daily. Replace worn or damaged parts immediately.
 	<p>EQUIPMENT MISUSE HAZARD</p> <p>Misuse can cause death or serious injury.</p> <ul style="list-style-type: none"> • Do not operate the unit when fatigued or under the influence of drugs or alcohol. • Do not exceed the maximum working pressure or temperature rating of the lowest rated system component. See Technical Data in all equipment manuals. • Use fluids and solvents that are compatible with equipment wetted parts. See Technical Data in all equipment manuals. Read fluid and solvent manufacturer's warnings. For complete information about your material, request Safety Data Sheet (SDS) from distributor or retailer. • Turn off all equipment and follow the Pressure Relief Procedure when equipment is not in use. • Check equipment daily. Repair or replace worn or damaged parts immediately with genuine manufacturer's replacement parts only. • Do not alter or modify equipment. Alterations or modifications may void agency approvals and create safety hazards. • Make sure all equipment is rated and approved for the environment in which you are using it. • Use equipment only for its intended purpose. Call your distributor for information. • Route fluid lines and cables away from traffic areas, sharp edges, moving parts, and hot surfaces. • Do not kink or over bend fluid lines or use fluid lines to pull equipment. • Keep children and animals away from work area. • Comply with all applicable safety regulations.
	<p>PRESSURIZED ALUMINUM PARTS HAZARD</p> <p>Use of fluids that are incompatible with aluminum in pressurized equipment can cause serious chemical reaction and equipment rupture. Failure to follow this warning can result in death, serious injury, or property damage.</p> <ul style="list-style-type: none"> • Do not use 1,1,1-trichloroethane, methylene chloride, other halogenated hydrocarbon solvents or fluids containing such solvents. • Do not use chlorine bleach. • Many other fluids may contain chemicals that can react with aluminum. Contact your material supplier for compatibility.

 <h1 style="margin: 0;">WARNING</h1>	
  	<p>THERMAL EXPANSION HAZARD</p> <p>Fluids subjected to heat in confined spaces, including lines, can create a rapid rise in pressure due to the thermal expansion. Over-pressurization can result in equipment rupture and serious injury.</p> <ul style="list-style-type: none"> Open a valve to relieve the fluid expansion during heating. Replace lines proactively at regular intervals based on your operating conditions.
	<p>TOXIC FLUID OR FUMES HAZARD</p> <p>Toxic fluids or fumes can cause serious injury or death if splashed in the eyes or on skin, inhaled, or swallowed.</p> <ul style="list-style-type: none"> Read Safety Data Sheets (SDSs) to know the specific hazards of the fluids you are using. Store hazardous fluid in approved containers, and dispose of it according to applicable guidelines.
	<p>BURN HAZARD</p> <p>Equipment surfaces and fluid that's heated can become very hot during operation. To avoid severe burns:</p> <ul style="list-style-type: none"> Do not touch hot fluid or equipment.
	<p>PERSONAL PROTECTIVE EQUIPMENT</p> <p>Wear appropriate protective equipment when in the work area to help prevent serious injury, including eye injury, hearing loss, inhalation of toxic fumes, and burns. This protective equipment includes but is not limited to:</p> <ul style="list-style-type: none"> Protective eyewear, and hearing protection. Respirators, protective clothing, and gloves as recommended by the fluid and solvent manufacturer.

Configuration Number Matrix for VA-EH25 Food Grade Pumps

Check the identification plate (ID) for the Configuration Number of your pump. Use the following matrix to define the components of your pump.

When you receive your pump, record the 8 character part number found on the shipping box (e.g., 811.0018):

Also record the configuration number on the pump ID plate to assist you when ordering replacement parts:

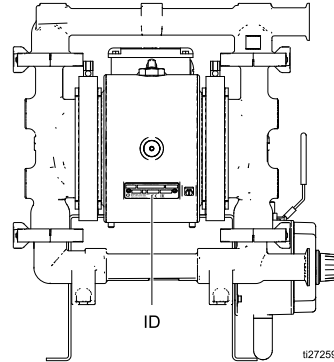

Sample Configuration Number: **VA-EH25SA-SENWSPT4ACFD21**

VA-EH	25	S	A	SE	NW	SP	T4	AC	FD	21
Pump Model	Pump Size	Wetted Parts	Center Section	Seats	Balls	Diaphragms	Connections	Drive	Options	Certifications

NOTE: Some combinations are not possible. Please check with your local supplier.

Pump	Pump Size		Wetted Parts		Center Section Material		Seat Material		Ball Material	
	VA-EH	25	25 mm	S	Sanitary Stainless Steel	A	Aluminum	SE	Sanitary Stainless Steel with EPDM o-rings	NW
					S	Sanitary Stainless Steel	ST	Sanitary Stainless Steel with PTFE o-rings	SP	Santo-prene
									TF	PTFE

Continued on the next page

Configuration Number Matrix for VA-EH25 Food Grade Pumps

Diaphragm Material		Connections		Drive		Options		Certification	
TO	PTFE/EPDM Overmolded	D4	40 mm DIN 11851	AC	Standard AC Induction, high speed gear ratio	FD	Food Grade	21	EN 10204 type 2.1
TF	2-Piece PTFE/EPDM	T4	1.5 in. Tri-Clamp	A1	Standard AC Induction, high speed gear ratio, 120V air compressor			31	EN 10204 type 3.1
SP	Santoprene			A2	Standard AC Induction, high speed gear ratio, 240V air compressor				
				AX ◆	ATEX AC Induction, high speed gear ratio				
				AF	Flameproof AC Induction, high speed gear ratio				
				BC	Standard AC Induction, low speed gear ratio				
				B1	Standard AC Induction, low speed gear ratio, 120V air compressor				
				B2	Standard AC Induction, low speed gear ratio, 240V air compressor				
				BX ◆	ATEX AC Induction, low speed gear ratio				
				NG ‡	None — NEMA 56 C Gearbox only				
				IG ‡	None — IEC 90 B5 Flange Gearbox only				

Configuration Number Matrix for VA-E2H25 High Sanitary Pumps

Check the identification plate (ID) for the Configuration Number of your pump. Use the following matrix to define the components of your pump.

When you receive your pump, record the 8 character part number found on the shipping box (e.g., 811.0018):

Also record the configuration number on the pump ID plate to assist you when ordering replacement parts:

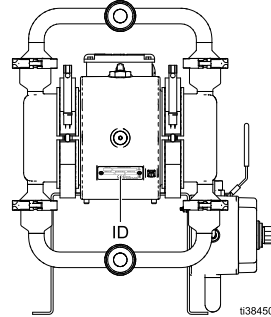

Sample Configuration Number: **VA-E2H25XS-STTFTST2AXSB21**

VA-E2H	25	X	S	ST	TF	TS	T2	AX	SB	21
Pump Model	Pump Size	Wetted Parts	Center Section	Seats	Balls	Diaphragms	Connections	Drive	Options	Certifications

NOTE: Some combinations are not possible. Please check with your local supplier.





Pump	Pump Size		Wetted Parts		Center Section Material		Seat Material		Ball Material	
	VA-E2H	25	25 mm	X	High Sanitary, 3-A 0.8 µm	S	Sanitary Stainless Steel	SE	Sanitary Stainless Steel with EPDM gasket seals	NW
			Y	Pharmaceutical 0.5 µm			ST	Sanitary Stainless Steel with TF-EP gasket seals	SP	Santo- prene
							SB	Sanitary Stainless Steel with Buna-N gasket seals	TF	PTFE
							SV	Sanitary Stainless Steel with FKM gasket seals	BN	Buna-N

Continued on the next page

Configuration Number Matrix for VA-E2H25 High Sanitary Pumps

Diaphragm Material		Connections		Drive		Options		Certification	
TO	PTFE/EPDM Overmolded	D2	25 mm DIN 11851	AC	Standard AC Induction, high speed gear ratio	SB	Sanitary ball	21	EN 10204 type 2.1
SP	Santoprene	T2	1 in. Tri-Clamp	A1	Standard AC Induction, high speed gear ratio, 120V air compressor			31	EN 10204 type 3.1
BN	Buna-N			A2	Standard AC Induction, high speed gear ratio, 240V air compressor				
TS	2-piece PTFE/Santoprene			AX ◆	ATEX AC Induction, high speed gear ratio				
				AF	Flameproof AC Induction, high speed gear ratio				
				BC	Standard AC Induction, low speed gear ratio				
				B1	Standard AC Induction, low speed gear ratio, 120V air compressor				
				B2	Standard AC Induction, low speed gear ratio, 240V air compressor				
				BX ◆	ATEX AC Induction, low speed gear ratio				
				NG ‡	None — NEMA 56 C Gearbox only				
				IG ‡	None — IEC 90 B5 Flange Gearbox only				

Approvals

Approvals	
All models (except AF) are approved to:	
*Diaphragm materials coded TO , TF, or TS combined with ball materials coded TF comply with:	 EC 1935/2004
‡ Pumps with code NG or IG are approved to:	 II 2 G Ex h IIB T3 Gb
◆ Aluminum and stainless steel pumps with code AX and BX are approved to:	 II 2 G Ex d h IIB T3 Gb
Diaphragm materials coded TS combined with ball materials coded TF comply with:	 Class VI

* EC 1935/2004 compliant pumps may be subject to individual national provisions in addition to those specified in the EC regulation. It is the users responsibility to know and follow local laws.

Overview

The product line offers electric-powered diaphragm pumps in a wide range of models. This section shows the structure of available models.

Center Section	Motor Type (Drive)	Gearbox	Compressor	Approval Options
Aluminum or Stainless Steel	AC, BC	Yes – part of motor	No†	CE
	A1, B1	Yes – part of motor	Yes – 120 V	None
	A2, B2	Yes – part of motor	Yes – 220 V	CE
	IG, NG	NEMA	No†	ATEX & CE
		IEC		
AX, BX	IEC	No†	ATEX & CE	

† Compressor Kits 859.0465 (120V) and 859.0466 (220V) are available

Key Points:

- Pumps are available with an AC gearmotor or with just a gearbox (for applications where a motor is already available).
- Verder recommends the use of a motor soft starter or a VFD in the electrical circuit for all installations.

See the motor manufacturer’s recommendations for proper installation when using either of these components. In all cases, make sure all products are installed in accordance with local codes and regulations.

Troubleshooting

- Follow the [Pressure Relief Procedure, page 14](#), before checking or servicing the equipment.
- Check all possible problems and causes before disassembly.



Problem	Cause	Solution
Pump cycles but will not prime and/or pump.	Pump is running too fast, causing cavitation before prime.	Slow down the motor controller (VFD)
	Center section has no air pressure, or air pressure is too low.	Apply air pressure to center section per your application requirements.
	Check valve ball is severely worn or wedged in seat or manifold.	Replace the ball and seat.
	Insufficient suction pressure	Increase suction pressure. See manual 859.0530.
	Seat is severely worn.	Replace the ball and seat.
	Outlet or inlet is restricted.	Remove the restriction.
	Inlet fittings or manifolds are loose.	Tighten.
	Manifold o-rings are damaged.	Replace o-rings.
The center section is excessively hot.	The drive shaft is broken.	Replace.
Pump fails to hold fluid pressure at stall.	Check valve balls, seats, or o-rings are worn.	Replace.
	Manifold clamps or fluid cover clamps are loose.	Tighten.
	Diaphragm shaft bolt is loose	Tighten.
Pump will not cycle.	Motor or controller is wired improperly.	Wire per manual.
	The leak detector (if installed) has tripped.	Check diaphragm for rupture or incorrect installation. Repair or replace.
Reduced pump performance.	Suction line is clogged.	Inspect; clear.
	Check balls are sticky or leaking.	Clean or replace.
	Diaphragm (or backup) ruptured.	Replace.
Pump makes unusual noises.	Pump is operating near or at stall pressure.	Adjust air pressure or slow the pump speed.
Air consumption is higher than expected.	A fitting is loose.	Tighten. Inspect thread sealant.
	Loose or damaged o-rings or shaft seal.	Replace.
	Diaphragm (or backup) ruptured.	Replace.

Problem	Cause	Solution
Air bubbles in fluid.	Suction line is loose.	Tighten.
	Diaphragm (or backup) ruptured.	Replace.
	Loose manifolds, damaged seats or o-rings.	Tighten manifold bolts or replace seats or o-rings.
	Loose diaphragm shaft bolt.	Tighten.
Pump leaks fluid externally from joints.	Loose manifold clamps or fluid cover clamps.	Tighten.
	Manifold o-rings worn out.	Replace o-rings.
The controller faults or shuts down.	A GFCI has tripped.	Remove the controller from the GFCI circuit.
	Supply power is poor.	Determine and fix the source of the power problem.
	Operational parameters are exceeded.	See manual 859.0530 for event codes.
NOTE: For problems with a Variable Frequency Drive (VFD), see your VFD manual.		

Repair

Pressure Relief Procedure



Follow the Pressure Relief Procedure whenever you see this symbol.



This equipment stays pressurized until pressure is manually relieved. To help prevent serious injury from pressurized fluid, such as splashing fluid, follow the Pressure Relief Procedure when you stop dispensing and before cleaning, checking, or servicing the equipment.

1. Turn off the pump and disconnect power to the system.
2. Close the master air valve (J) to shut off the air to the pump.
3. Open the fluid drain valve (L) to relieve fluid pressure. Have a container ready to catch the drainage.
4. Close the pump air inlet valve (E) on the pneumatic enclosure.

Check Valve Repair

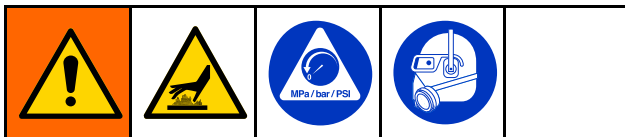

NOTE: Kits are available for new check valve balls, diaphragms, and manifold o-rings in a range of

materials. A seat and manifold o-ring kit is also available.

NOTE: To ensure proper seating of the check balls, always inspect the seats when replacing the balls. Replace seats as necessary if seating surface shows evidence of wear.

Disassemble the Check Valves

1. Follow the [Pressure Relief Procedure, page 14](#). Remove power from the motor. Disconnect all fluid and air lines.
2. Remove the manifold clamps (6), then remove the outlet manifold (3).
3. Remove the ball check assemblies:
 - a. On VA-EH25 pumps, remove the o-rings (9), seats (7), and balls (8).
 - b. On VA-E2H25 pumps, remove the ball stops (8), gaskets (9), and balls (8).
4. Repeat for the inlet manifold (4), o-rings (9), seats (7), and balls (8).
5. To continue with diaphragm disassembly, see [Disassemble the Diaphragms, page 16](#).

Reassemble the Check Valves

1. Clean all parts and inspect for wear or damage. Replace parts as needed.
2. Reassemble in the reverse order, following all notes in the illustration. Put the inlet manifold on first. Be sure the ball checks (7–9) and manifolds (3, 4) are assembled **exactly** as shown. The arrows on the fluid covers (2) **must** point toward the outlet manifold (3).

VA-EH25

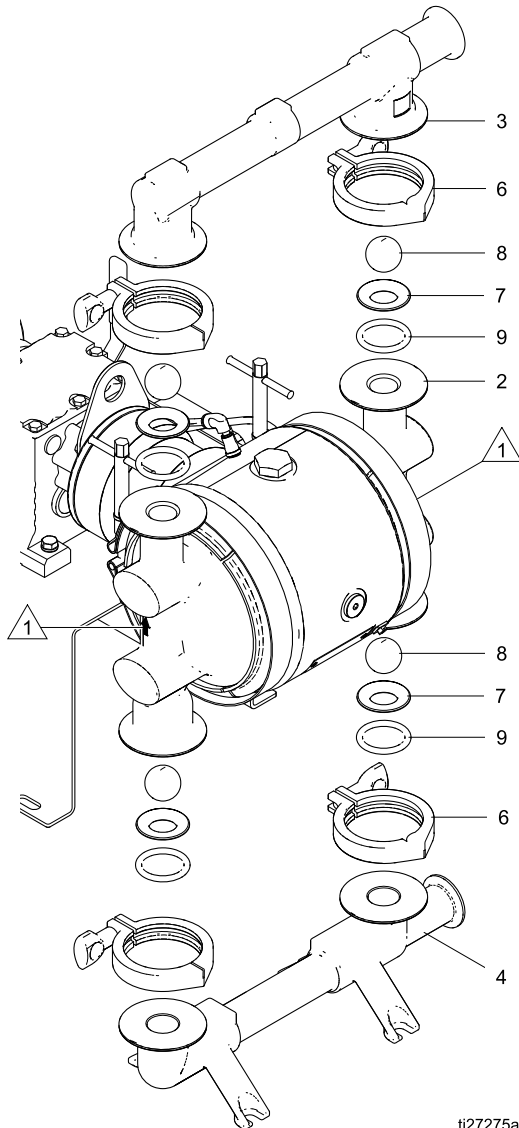

ti27275a

1 Arrow on both covers must point toward outlet manifold

VA-E2H25

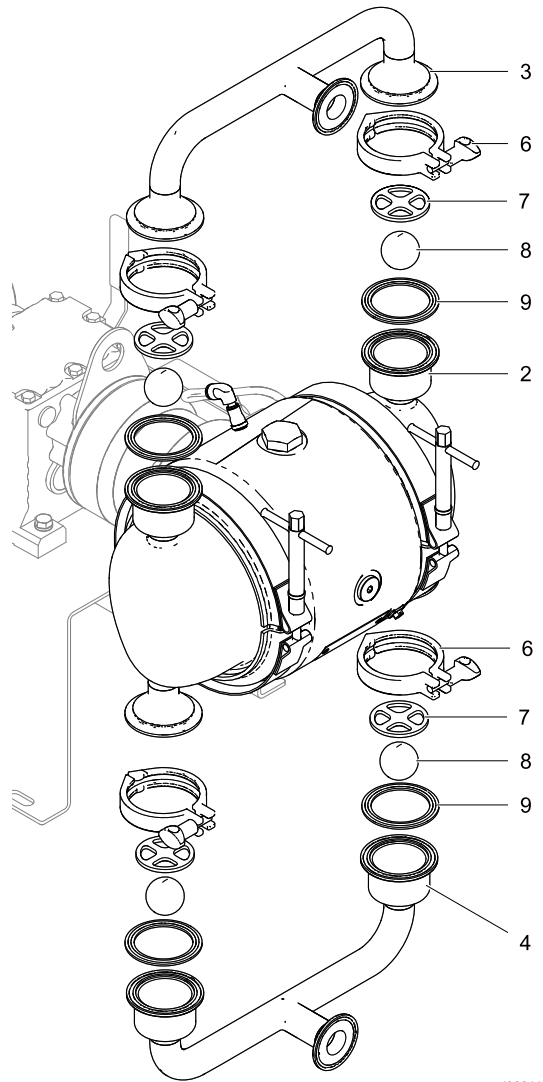

i36641a

Diaphragm Repair

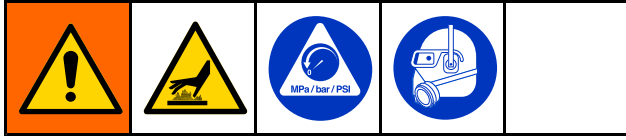

Disassemble the Diaphragms

NOTE: Diaphragm kits are available in a range of materials and styles. See Parts section.

1. Follow the [Pressure Relief Procedure, page 14](#). Remove power from the motor. Disconnect all hoses.
2. Remove the manifolds and disassemble the ball check valves as explained in [Check Valve Repair, page 14](#).
3. Remove the clamps (5) from the fluid covers, then pull the fluid covers off of the pump.

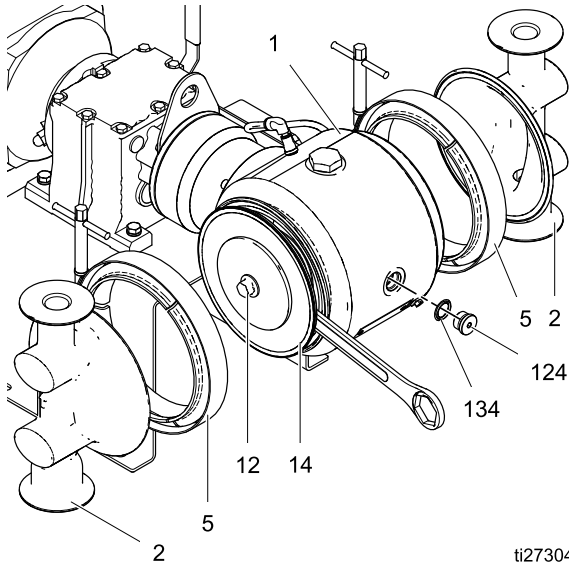

ti27304a

4. Loosen the screws and remove the motor fan cover. Turn the motor fan by hand to move the piston fully to one side.

NOTE: If the pump is still attached to the motor, remove the plug (124) and o-ring (134). Use a 10 mm socket to rotate the shaft clockwise to shift the piston to one side. Socket should move easily [no more than 1.7 N•m (15 in-lb) of torque]. If more torque is required, stop. Remove the motor. See [Center Section Repair, page 19](#).

5. **Overmolded Diaphragms (TO models)**
 - a. Hold a 5/8 in. wrench on the wrench flats of the exposed piston shaft. The diaphragm (12) will screw off by hand. Remove the air side diaphragm plate (11).
 - b. Turn the motor fan to move the piston fully to the other side by rotating the drive shaft. Repeat step 5a.
6. **All Other Diaphragms**
 - a. Hold a 5/8 in. wrench on the wrench flats of the exposed piston shaft. Use a 15 mm wrench on the shaft bolt (15) to remove it. Then remove all parts of the diaphragm assembly.
 - b. Turn the motor fan to move the piston fully to the other side by rotating the drive shaft. Repeat step 6a.
7. To continue with diaphragm disassembly, see [Disassemble the Center Section, page 19](#).

Reassemble the Diaphragms

Follow all notes in the illustrations on page 18. These notes contain **important** information.

NOTICE

After reassembly, allow the thread locker to cure for 12 hours, or per manufacturer's instructions, prior to operating the pump. Damage to the pump will occur if the diaphragm shaft bolt loosens.

TIP: If you are also repairing or servicing the center section (drive shaft, piston, etc.), follow [Center Section Repair, page 19](#), before replacing diaphragms.

1. Clean all parts and inspect for wear or damage. Replace parts as needed. Be sure the center section is clean and dry.
2. **Overmolded Diaphragms (TO)**
 - a. If a diaphragm setscrew comes loose or is replaced, apply permanent (red) thread locker to diaphragm side threads. Screw into diaphragm until tight.
 - b. Assemble the air side plate (11) onto the diaphragm. The rounded side of the plate must face the diaphragm.
 - c. Clean the female threads of the piston shaft with a wire brush dipped in solvent to remove any residual thread locker. Apply thread-locking primer and allow it to dry.
 - d. Thoroughly clean, then apply medium-strength (blue) thread locker to the threads of the diaphragm assembly.
 - e. Hold a 5/8 in. wrench on the wrench flats of the piston shaft. Screw the assembly into the shaft as tight as possible by hand.
 - f. Turn the motor fan to move the piston fully to the one side by rotating the drive shaft. See instructions in step 4 of [Disassemble the Diaphragms, page 16](#).
 - g. Repeat to install the other diaphragm assembly.
3. **All Other Diaphragms—Metal Pumps**
 - a. Thoroughly clean or replace the diaphragm bolt (14). Install the o-ring (15).
 - b. Assemble the fluid side plate (10), the diaphragm (12), the backup diaphragm (13, if present), and the air side diaphragm plate (11) on the bolt exactly as shown.
 - c. Clean the female threads of the piston shaft with a wire brush dipped in solvent to remove any residual thread locker. Apply thread-locking primer and allow it to dry.
 - d. Apply medium-strength (blue) thread locker to the threads of the bolt.
 - e. Hold a 5/8 in. wrench on the wrench flats of the piston shaft. Screw the bolt onto the shaft and torque to 81–95 N•m (60–70 ft-lb).
 - f. Turn the motor fan to move the piston fully to the other side by rotating the drive shaft. See instructions in step 4 of [Disassemble the Diaphragms, page 16](#).
 - g. Repeat to install the other diaphragm assembly.
4. Attach the fluid covers. The arrow on each fluid cover must point toward the outlet manifold. Tighten the mounting clamp (5).

NOTE: Lubricate the inner surface of the clamp with a food grade waterproof sanitary lubricant. A food grade anti-seize lubricant can be used on the clamp threads to aid assembly.
5. Reassemble the check valves and manifolds. See [Reassemble the Check Valves, page 14](#).

Repair

- 1 Rounded side faces diaphragm.
- 2 Apply medium-strength (blue) thread locker to the threads.
- 3 AIR SIDE markings on diaphragm must face the center housing.
- 4 If the screw comes loose or is replaced, apply permanent (red) thread locker to diaphragm side threads. Apply medium-strength (blue) thread locker to shaft side threads.
- 5 Torque to 81–95 N•m (60–70 ft-lb) at 100 rpm maximum.
- 6 Apply primer to the female threads. Allow to dry.

2-Piece (TF and TS) Models

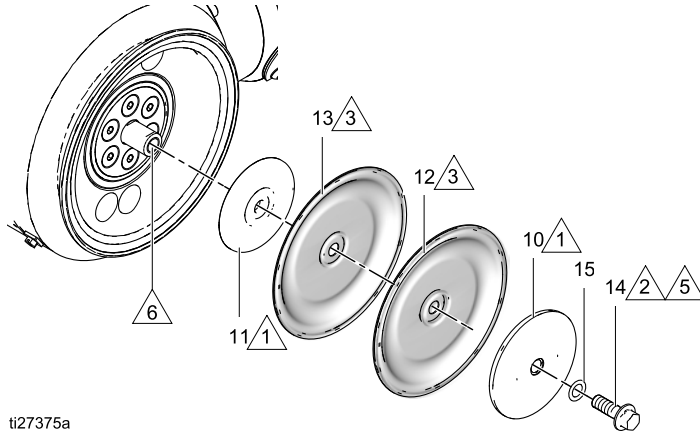

Overmolded (TO) Models

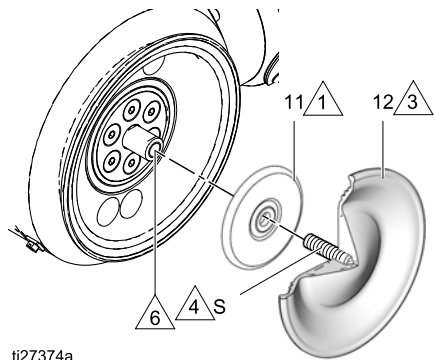

Standard (SP and BN) Models

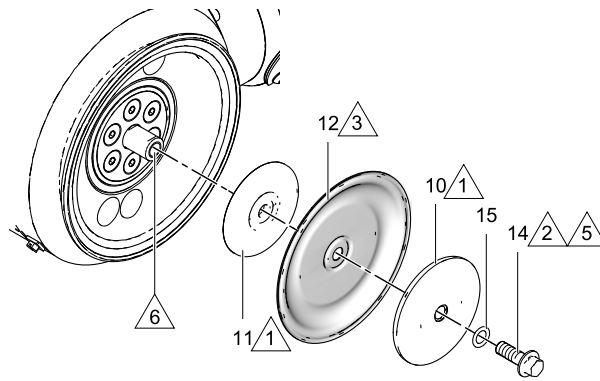

NOTICE

After reassembly, allow the thread locker to cure for 12 hours, or per manufacturer's instructions, prior to operating the pump. Damage to the pump will occur if the diaphragm shaft bolt loosens.

Center Section Repair

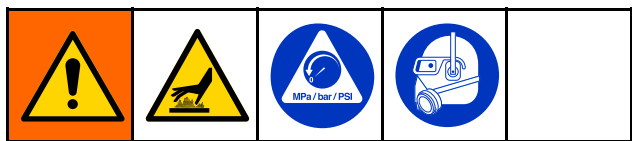

Disassemble the Center Section

See the illustrations on page 20.

1. Follow the [Pressure Relief Procedure, page 14](#). Disconnect all fluid and air lines.
2. Remove the manifolds and check valve parts as directed in [Disassemble the Check Valves, page 14](#).
3. Remove the fluid covers and diaphragms as directed in [Disassemble the Diaphragms, page 16](#).
TIP: Clamp the gear box bracket (27) to the bench. Leave the pump connected to the motor.
4. Use a 5 mm hex wrench to remove 4 bolts (117). Pull the pump off of the alignment housing (116).
TIP: It may be necessary to tap the pump with a rubber mallet to disengage the coupler.
5. Use a 5/16 hex wrench to remove the plug (124). Use a 30 mm socket wrench to remove the bearing bolt (106) and the o-ring (108) from the top.
6. Turn the shaft so the groove (G) on the drive shaft (112) is at the top, in line with the alignment mark (A) on the center housing.

7. Use a 3/4–16 bolt, screwed into the hole for plug (124), to push out the drive shaft (112). You can also use the bearing bolt (106), but remove the bearing (107) first. Be sure that the groove on the drive shaft remains aligned with the markings in the center section.

NOTICE

Proper alignment is essential. Do not apply more than about 1.1 N•m (10 in-lb) of torque. Excessive torque could strip the housing thread. If you encounter resistance, check drive shaft alignment or contact your distributor.

8. Remove the seal cartridge (110), the o-ring (109) and the radial seal (111) with o-ring (111a).
9. Slide the piston assembly (102) out of the center.
10. Leave the gearbox coupler (114) attached to the gearbox (118) shaft unless it is damaged. If you need to remove it, first remove the alignment housing (116). Use an 8 mm hex wrench to loosen the screw (115), then remove the gearbox coupler (114).

NOTE: If the coupler does not come off freely, use a bearing puller to remove it. Do not use any prying tools, as damage to the mounting flange on the gearbox could occur.

Repair

- △1 Apply medium-strength (blue) thread locker to threads.
- △2 Torque to 20–34 N•m (15–25 ft-lb).
- △3 Lips must face **IN** toward the center.
- △4 Apply anti-seize lubricant liberally on the surfaces of the drive shaft assembly.
- △5 Install the drive shaft assembly with the groove facing up.
- △6 Tighten screws in a crisscross pattern, 5 turns at a time, to engage the coupler evenly. Torque to 15–18 N•m (130–160 in-lb).
- △7 Apply lubricant to inner mating surface.

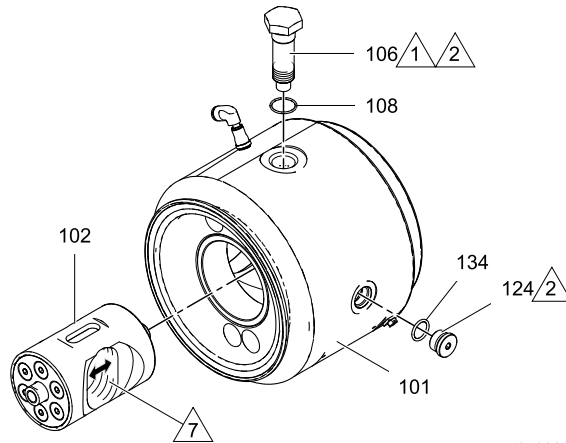

ti27322a

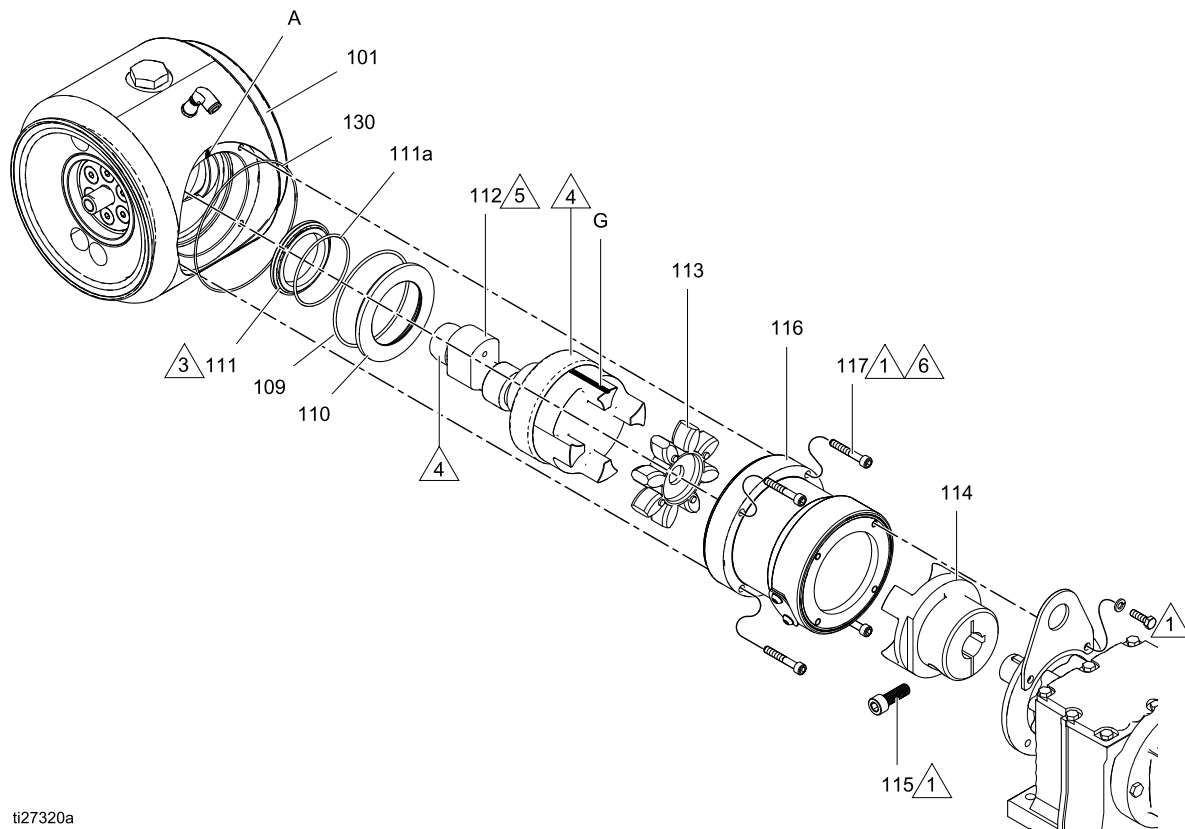

ti27320a

Reassemble the Center Section

See the illustrations on the previous page.

1. Clean and dry the center housing (101), the center of the piston (102) and the drive shaft (112).
2. Inspect the piston for excessive wear and replace if needed. Grease the piston as shown on page 18 and install it in the center section with the groove on the top, in line with the bearing bolt (106) hole in the center section.
3. Install the bearing (107 [if removed from the bearing bolt]), o-ring (108), and the bearing bolt (106). Apply medium-strength (blue) thread locker to the bearing bolt. Be sure that the bearing (107) is in the groove on the piston, as shown. Be sure that the piston moves freely. Torque the bolt to 20–34 N•m (15–25 ft-lb).

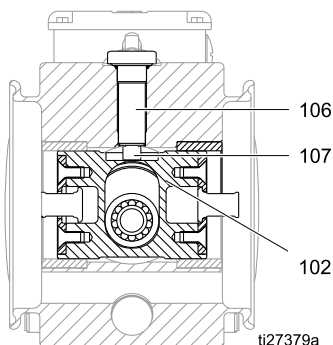

4. Be sure the sealing surface of the drive shaft (112) is clean. Install the seal cartridge (110†) and the radial seal (111†) on the drive shaft. Be sure the o-ring (111a†) is on the radial seal. The lips on the radial seal (111†) must face **IN** toward the center.

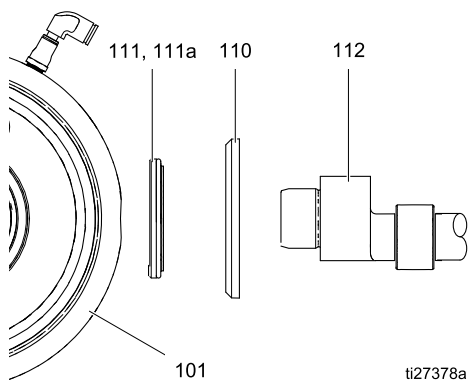

5. Install o-ring (109†).
6. Apply anti-seize lubricant on the mating surfaces of the drive shaft, as shown in the illustration, page 18.
7. Center the piston in the housing and install the drive shaft assembly (112), with the groove (G) facing up, into the center housing (101).
8. Inspect the shaft coupler (114) for wear and replace if needed. Install on the drive shaft.
9. If removed, install the gearbox coupler (114) on the shaft. Apply medium strength thread locker and install the screw (115). Torque to 47–61 N•m (35–45 ft-lb). Then install the alignment housing (116) and lifting bracket (139) on the gearbox using the screws (120, 122), washers (119). Torque to 15–18 N•m (130–160 in-lb).
10. Install the alignment housing o-ring (130) on the housing (101).
11. Be sure the gearbox coupler (114) is aligned properly. Turn by hand if needed. Connect the pump to the gearbox assembly, engaging the couplers.
12. Apply medium-strength (blue) thread locker and install the housing screws (117). Tighten about 5 turns at a time, in a crisscross pattern, to fully engage the coupler. Torque to 15–18 N•m (130–160 in-lb).
13. Be sure o-ring (134) is on the plug (124). Install the plug and torque to 20–34 N•m (15–25 ft-lb).
14. See [Reassemble the Diaphragms, page 17](#), and [Reassemble the Check Valves, page 14](#).

Replace Center Bearing

NOTE: Follow this procedure only if you suspect that the center bearing is damaged. It is not necessary to replace the bearing for normal pump service. You will need Center Section Repair Tool Kit 859.0507. You also will need Bearing Puller Kit 859.0529. The tool (A) was designed to work with this bearing puller.

1. Follow all steps in [Disassemble the Center Section, page 19](#).
2. Clamp the center housing (101) in a vise, with one of the bushings facing up.
3. Place the repair tool (A) on the housing with the grooved side down.
4. Remove the bushing (C). Use the upper holes on the medium-sized jaw, and the inner holes on the puller. Be sure that the jaws engage the bottom rim of the bushing. When one bushing is out, turn the housing over and repeat for the other bushing.

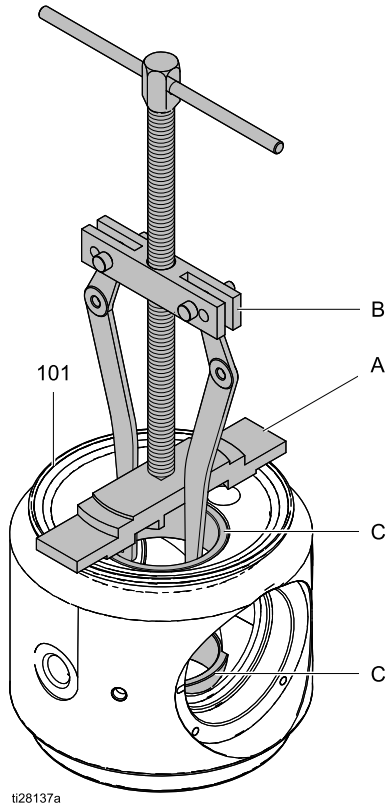

5. Place the center housing (101) in the vise with the bearing (D) side on the bottom.

6. Place the repair tool (A) on the housing with the stepped side down.
7. Remove the bearing (D). Use the lower holes on the medium-sized jaw, and the outer holes on the puller.

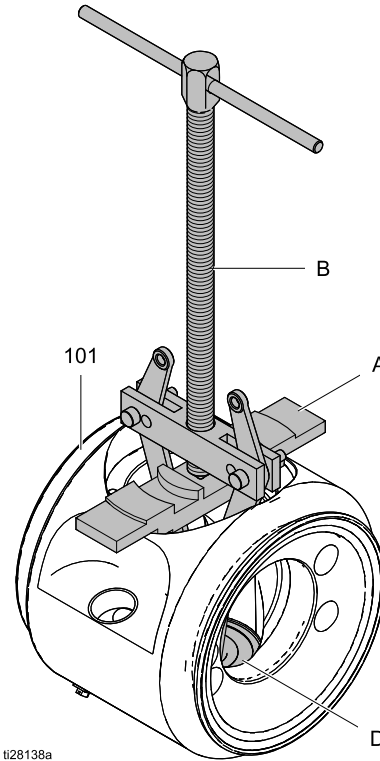

8. Use an arbor press to install the new bearing (D) into the center housing (101). Press the bearing to the shoulder in the center housing.

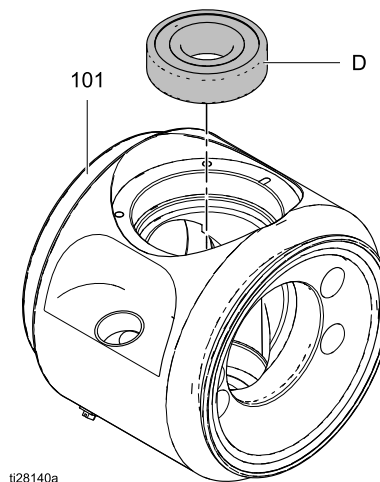

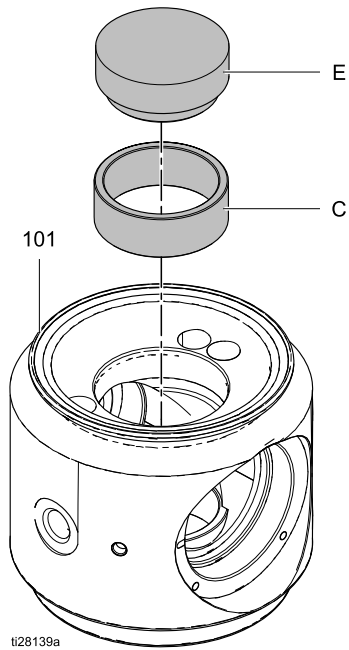

9. Use an arbor press and the press-fit tool (E) to install the two bushings (C). Install the bushings flush with the center housing (101).



10. Follow all steps in [Reassemble the Center Section, page 21](#).

Replace the Compressor

				
<p>To avoid injury from fire, explosion, or electric shock, all electrical wiring must be done by a qualified electrician and comply with all local codes and regulations.</p>				

1. Follow the [Pressure Relief Procedure, page 14](#), and disconnect power.
2. Remove the air line (A1) from the compressor. Disconnect the compressor wires at the terminal block (L1, L2, and ground). Remove the four bolts, and carefully pull the compressor out of the box.
3. Use the 4 bolts and 4 lock washers to install the new compressor. Apply medium-strength (blue) thread locker to the threads. Connect the air line from A1 to A1, as shown.
4. Connect the wires from the new compressor to the terminal block, as shown.
5. Return the pump to its mounting location. Secure it with the 8 bolts.
6. Return power to the pump.

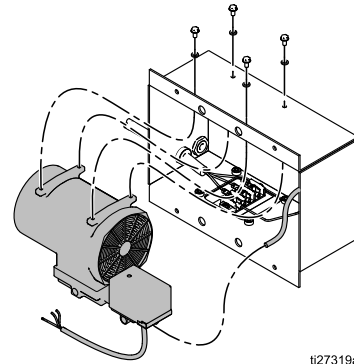

ti27319a

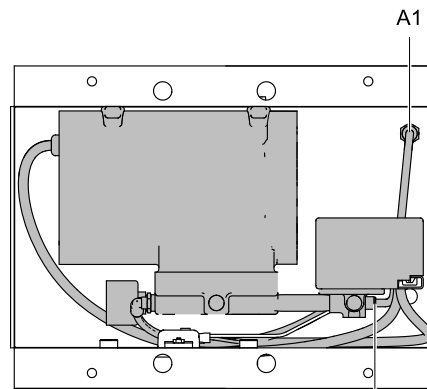

ti27318a

A1

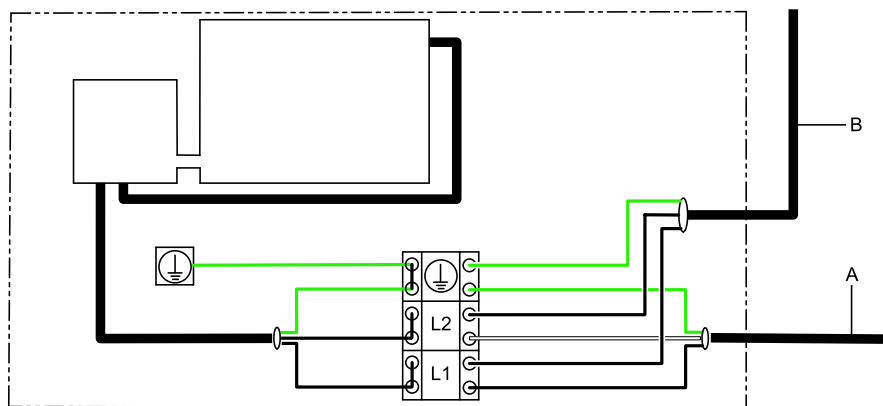

KEY

- A To power supply
- B To controller

Parts

VA-EH25

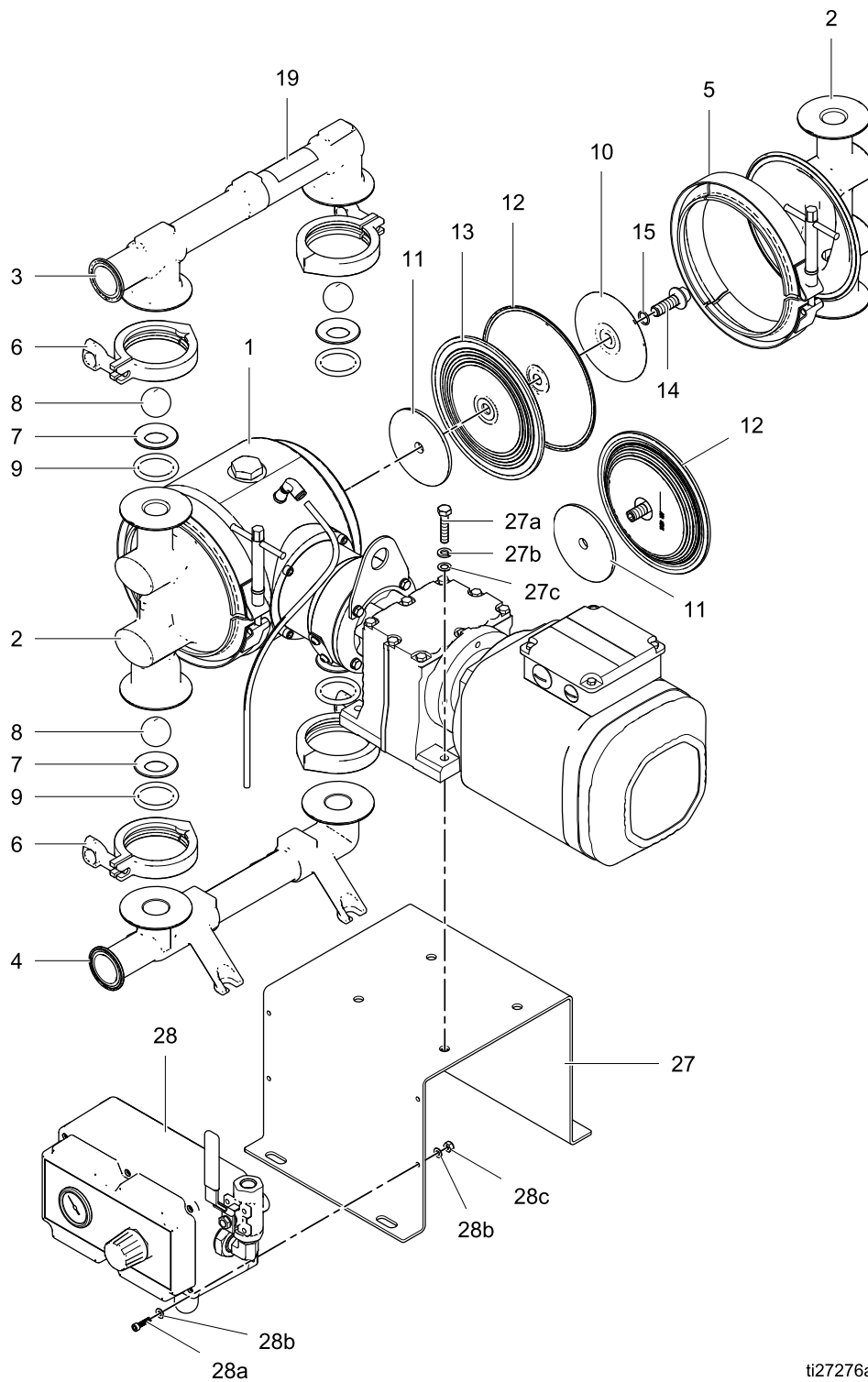

ti27276a

VA-EH25 Parts/Kits Quick Reference

Use this table as a quick reference for parts/kits. Go to the pages indicated in the table for a full description of kit contents.

Ref.	Part/Kit	Description	Qty.
1	— — —	MODULE, drive	1
2	819.0490	COVER, fluid	2
3	819.0494 819.0618	MANIFOLD, outlet, SST Tri-Clamp DIN	1
4	819.0493 819.0617	MANIFOLD, inlet, SST Tri-Clamp DIN	1
5	819.0522	CLAMP, cover	2
6	819.0505	CLAMP, Tri-Clamp	4
7*	819.0537	SEAT, includes o-rings (Ref. 9); <i>see page 29</i>	4
8*	— — —	BALLS, check, pkg of 4; <i>see page 29</i>	1
9*	— — —	O-RING, manifold, pkg of 4; <i>see page 29</i>	1
10	819.0508	PLATE, fluid side, SST, not used with overmolded (TO) diaphragms	2
11	819.0446 819.0534	PLATE, air side, aluminum for TF & SP diaphragms for TO diaphragms	2
12*	— — — — — — — — —	DIAPHRAGM, kit; <i>see page 30</i> Santoprene Standard (SP) PTFE Overmolded (TO) PTFE/EPDM 2-Piece (TF)	1 kit

Ref.	Part/Kit	Description	Qty.
13*	— — —	DIAPHRAGM, backup, included with TF diaphragm (Ref. 12).	2
14	859.0085	BOLT, diaphragm; kit; includes o-ring (ref. 15), not used with overmolded (TO) diaphragms	2
15*	819.4304 or none	PACKING, o-ring, not used with overmolded (TO) diaphragms	2
19▲	812.0271	LABEL, safety	1
27	859.0464	BRACKET, gearbox mounting, includes 27a, 27b, 27c	1
27a	— — —	SCREW, cap, hex head, 5/16–18 x 1.5 in.	4
27b	— — —	WASHER, lock	4
27c	— — —	WASHER, flat,	4
28	859.0468	ENCLOSURE, pneumatic, includes 28a, 28b, 28c	1
28a	— — —	SCREW, cap, socket head, 10–24 x 3/4 in.	4
28b	— — —	WASHER	8
28c	— — —	NUT	4

▲ Replacement safety labels, signs, tags, and cards are available at no cost.

* Included in the fluid section repair kit, which may be purchased separately.

VA-E2H25

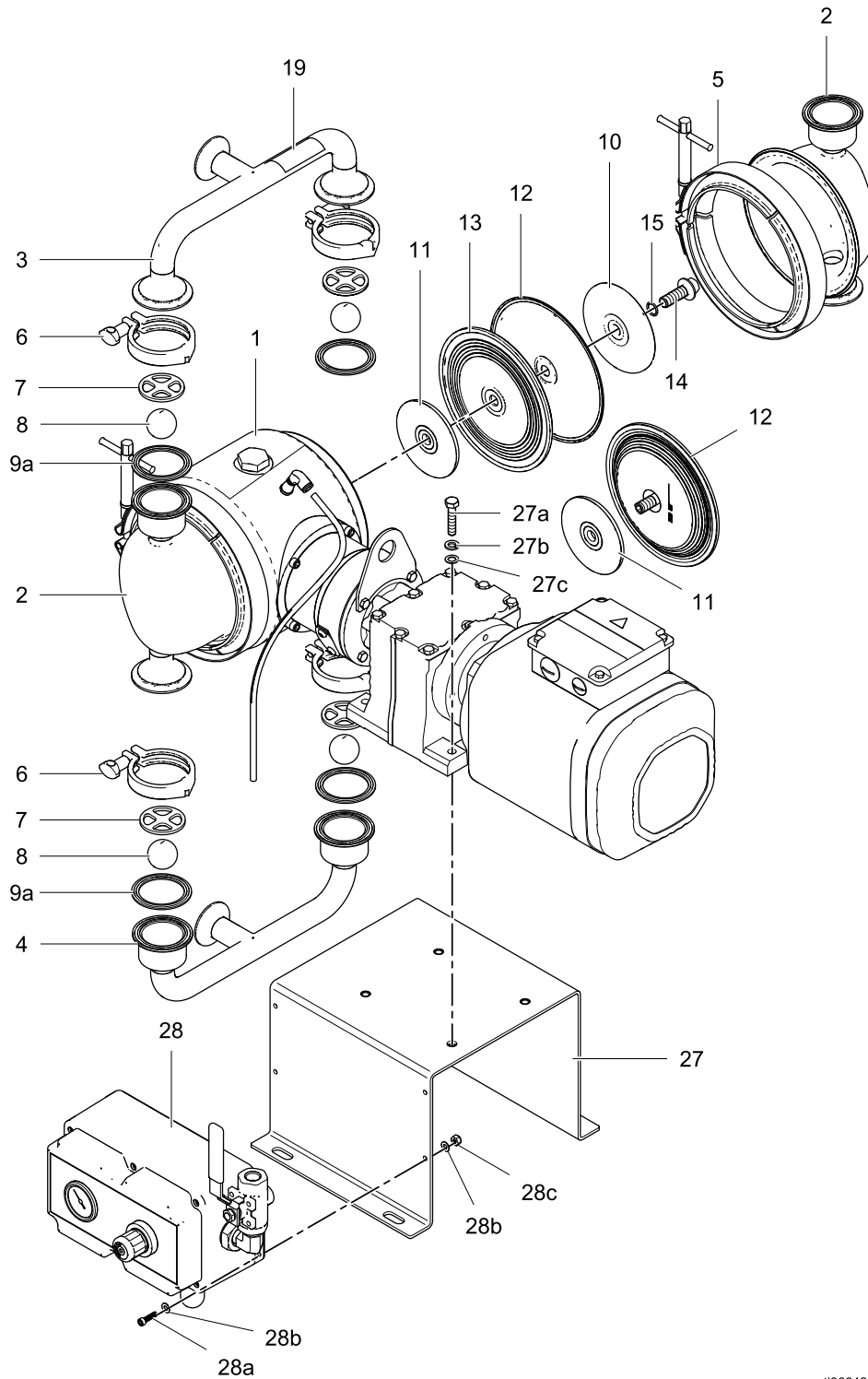

t336642a

VA-E2H25 Parts/Kits Quick Reference

Use this table as a quick reference for parts/kits. Go to the pages indicated in the table for a full description of kit contents.

Ref.	Part/Kit	Description	Qty.
1	— — —	MODULE, drive	1
2	812.0014 812.0023	COVER, fluid X Y	2
3	812.0027 812.0100	MANIFOLD, outlet X Y	1
4	812.0034 812.0099	MANIFOLD, inlet X Y	1
5	819.0522	CLAMP, cover	2
6	819.0503	CLAMP, TriClamp	4
7	812.0119	BALL STOP	4
8*	— — —	BALLS, check, pkg of 4; <i>see page 29</i>	1
9a*	— — —	GASKET, package of 4; <i>see page 29</i>	1
10	819.0411	PLATE, fluid side, SST, not used with overmolded (TO) diaphragms	2
11	819.4373 819.0534	PLATE, air side, aluminum for TS and SP diaphragms for TO diaphragms	2
12*	— — —	DIAPHRAGM, kit; <i>see pages 30–31</i>	1
13*	— — —	DIAPHRAGM, backup, included with TS diaphragm (Ref. 12).	2

Ref.	Part/Kit	Description	Qty.
14	859.0085	BOLT, diaphragm; kit; includes o-ring (ref. 15), not used with overmolded (TO) diaphragms	2
15*	819.4304 or none	PACKING, o-ring, not used with overmolded (TO) diaphragms	2
19▲	812.0136	LABEL, safety	1
27	859.0464	BRACKET, gearbox mounting, includes 27a, 27b, 27c	1
27a	— — —	SCREW, cap, hex head, 5/16–18 x 1.5 in.	4
27b	— — —	WASHER, lock	4
27c	— — —	WASHER, flat,	4
28	859.0468	ENCLOSURE, pneumatic, includes 28a, 28b, 28c	1
28a	— — —	SCREW, cap, socket head, 10–24 x 3/4 in.	4
28b	— — —	WASHER	8
28c	— — —	NUT	4

▲ Replacement safety labels, signs, tags, and cards are available at no cost.

* Included in the fluid section repair kit, which may be purchased separately.

Drive Module

Sample Configuration Number:

Pump Model	Pump Size	Wetted Parts	Center-Section	Seats	Balls	Diaphragms	Connections	Drive	Options	Certifications
VA-EH	25	X	S	ST	TF	TS	T2	AX	SB	21

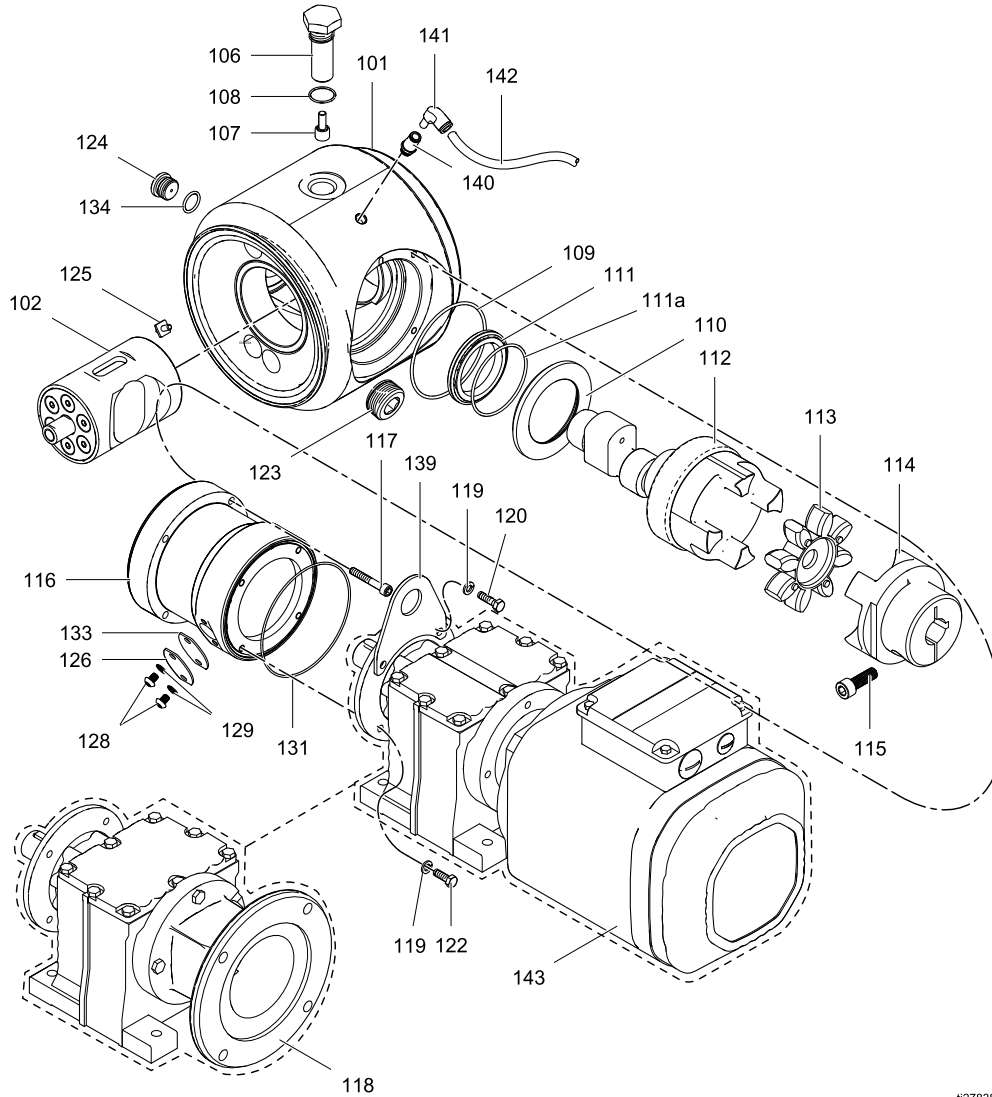

627838a

Parts

Ref	Part	Description	Qty
101	859.0461 859.0462	HOUSING, center, assembly; includes items (Ref. 123, 124, 134) Aluminum (A) Stainless Steel (S)	1
102	859.0509	PISTON, kit	1
106	859.0493 859.0494	BOLT, bearing; includes Ref. 107 and Ref. 108 for aluminum center housing (A) for stainless steel center housing (S)	1
107	— — —	BEARING, cam follower. included with Ref. 106	1
108	— — —	O-RING, Size 019, Fluoroelastomer; included with Ref. 106	1
109†	— — —	O-RING, Size 153, Buna-N	1
110†	— — —	CARTRIDGE, seal	1
111†	— — —	SEAL, radial, includes o-ring (Ref. 111a)	1
111a†	— — —	O-RING, seal	1
112	859.0485	SHAFT, drive, assembly; includes o-ring (Ref. 109), cartridge (Ref. 110) and seal (Ref. 111 and 111a)	1
113	859.0484	COUPLER, shaft	1
114	859.0483	COUPLER, gearbox; Includes screw (ref. 115)	1
115	— — —	SCREW, socket head, M10 x 30 mm	1
116	859.0470 859.0469	HOUSING, alignment, assembly; includes screws (Refs. 117 and 128) and access cover (Ref. 126) Aluminum Stainless steel	1

Ref	Part	Description	Qty
117	— — —	SCREW, socket head, M6 x 40 mm	4
118	859.0521 859.0520	GEARBOX, NEMA (NG) IEC (IG)	1
119	— — —	WASHER	4
120	— — —	SCREW, cap, hex head, M6 x 16 mm	2
122	— — —	SCREW, cap, hex head, M6 x 20 mm	2
123	— — —	PLUG, pipe, headless	1
124	859.0495	PLUG, front access includes o-ring (Ref. 134)	1
125	819.0220	SCREW, ground, M5 x 0.8	1
126	859.0471	COVER, access; includes items (Ref. 128, 129, 133)	1
128	— — —	SCREW, button head, M6 x 6 mm	2
129	— — —	WASHER	2
131	859.0472	PACKING, o-ring	1
132‡	— — —	SCREW, cap, hex head, 3/8–16 x 1 in. (BLDC only)	4
133	— — —	GASKET	1
134	— — —	O-RING	1
139	859.0534	RING, Lift	1
140▲	— — —	FITTING, 1/8 npt	1
141▲	— — —	FITTING, elbow	1
142▲	— — —	TUBE	1
143	859.0697	GEARMOTOR, AC; 50/60 Hz; includes items (Ref. 119, 120, 122)	1

† Included in Shaft Seal Repair Kit 859.0496.

▲ Included in Fitting Kit 859.0533.

Seats and Check Balls

Sample Configuration Number:

Pump Model	Pump Size	Wetted Parts	Center Section	Seats	Balls	Diaphragms	Connections	Drive	Options	Certifications
VA-EH	25	X	S	ST	TF	TS	T2	AX	SB	21

Ball Kits			
Ball Material	Kit	Description	Qty.
BN	812.0251	Kit, Ball-D1/E1 BN	1
NW	819.0545	Kit, Ball-D1/E1 NW	1
TF	819.0426	Kit, Ball-D1/E1 TF	1
SP	819.0427	Kit, Ball-D1/E1 SP	1

Kits include:

- 4 balls (8)

O-Ring Kits for VA-EH25 Pumps				
Seats	O-ring Material	Kit	Description	Qty.
SE	EP	819.0550	Kit, O-ring-D2 EP-4	1
ST	TF	819.0540	Kit, O-ring-D2 TF-4	1
---	TF-VT	819.1223	Kit, O-ring-D2 TF-VT	1

Kits include:

- 4 o-rings (9)

--- *not available*

Optional Sanitary Gasket Kits for VA-E2H25 Pumps				
Seats	Gasket Material	Kit	Description	Qty.
SB	BN	812.0243	Hygienic Gasket-D3 BN-4	1
SE	EP	812.0007	Hygienic Gasket-D3 EP-4	1
ST	TF-EP	812.0157	Hygienic Gasket-D3 TF-EP	1
SV	VT	812.0150	Hygienic Gasket-D3 VT-4	1

Kits include:

- 4 gaskets (9a)

Diaphragms

Sample Configuration Number:

Pump Model	Pump Size	Wetted Parts	Center Section	Seats	Balls	Diaphragms	Connections	Drive	Options	Certifications
VA-EH	25	X	S	ST	TF	TF	T2	AX	SB	21

Bolt-Through Diaphragm Kits		
Diaphragm Material	Kit	Qty.
BN	812.0258	1
SP	859.0480	1
TF	859.0481	1
TS	812.0123	1

Kits include:

- 2 diaphragms (12)
- 2 diaphragm backers (13), if applicable*
- 2 o-rings†
- 1 packet anaerobic adhesive

* *TF and TS diaphragms only*
 † *Only used with bolt-through diaphragms behind the bolt head. Not used in pump assemblies that use a stud threaded into the back side of the fluid plate.*

Overmolded Diaphragm Kit		
Diaphragm Material	Kit	Qty.
TO	819.1409	1

Kit includes:

- 2 overmolded diaphragms (12)
- 2 set screws (S) installed in the diaphragm

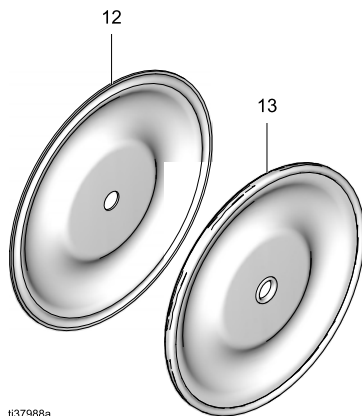
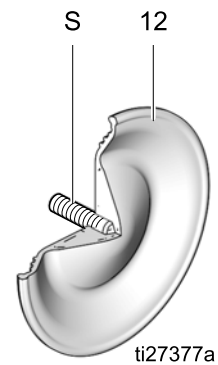

Sample Configuration Number:

Pump Model	Pump Size	Wetted Parts	Air Section	Seats	Balls	Diaphragms	Connections	Drive	Options	Certifications
VA-EH	25	X	S	ST	TF	TF	T2	AX	SB	21

Kit descriptions appear in the following order: *Pump model, seat material, ball material, diaphragm material, o-ring material*. For example, *VA-H25 --,NW,SP,EP*. Refer to the [Configuration Number Matrix for VA-EH25 Food Grade Pumps, page 6](#) to define the components.

Fluid Section Repair Kits for VA-EH25 Pumps			
Diaphragm Material	Kit	Description	Qty.
SP	859.0474	VA-H25 --,NW,SP,EP	1
TO	859.0475	VA-H25 --,TF,TO,TF	1
TF	859.0476	VA-H25 --,TF,TF,TF	1
SP	859.0478	VA-H25 --,SP,SP,EP	1

Kits include:

- 4 balls
- 2 diaphragms (12)
- 2 diaphragm backers (13), if applicable
- 4 seat o-rings
- 2 diaphragm o-rings (except for TO diaphragms)

Fluid Section Repair Kits for VA-E2H25 Pumps			
Diaphragm Material	Kit	Description	Qty.
BN	812.0176	VA-2H25X-Y --,BN,BN,BN	1
SP	812.0178	VA-2H25X-Y --,NW,SP,EP	1
TO	812.0180	VA-2H25X-Y --,TF,TO,TF	1
TS	812.0181	VA-2H25X-Y --,TF,TS,TF	1
SP	812.0182	VA-2H25X-Y --,TF,SP,EP	1
SP	812.0184	VA-2H25X-Y --,SP,SP,EP	1

Kits include:

- 4 balls
- 2 diaphragms (12)
- 2 diaphragm backers (13), if applicable
- 4 gaskets
- 2 diaphragm o-rings (except for TO diaphragms)
- 1 packet anaerobic sealant

Kits and Accessories

Leak Sensor Kit 859.0508

Upgrade kit, to add a leak sensor to an existing system. Includes leak sensor and bushing.

Leak Sensor Cables; Field Wireable (for VFDs)

M8, 4-pin

Part	Description
859.0517	9.8 ft; 3.0 m
859.0518	24.6 ft; 7.5 m
859.0519	52.5 ft; 16 m

Compressor Kits 859.0504 (120V) and 859.0505 (240V)

Kit contains only a compressor.

Compressor Upgrade Kits 859.0465 (120V) and 859.0466 (240V)

Upgrade kits include compressor, compressor box, brackets, and mounting hardware.

Center Section Repair Tool Kit 859.0507

Includes tools needed to remove the bearing from the center section.

Bearing Puller Kit 859.0529

Includes an interchangeable bearing puller set.

ATEX Motor Kit 859.0523

(For European hazardous locations)

Kit contains motor and SST mounting hardware. Motor is ATEX rated II2 G Ex d IIB T3 Gb; IP55. Mounting flange is IEC90 B5 and fits pumps with gearbox 859.0520 and pumps with gearbox and motor configuration code **IG**.

Explosion-Proof Motor Kit 859.0522

(For North American hazardous locations)

Kit contains motor and SST mounting hardware. Motor is rated Class I Group C & D; Class II Group F & G; IP54. Mounting flange face dimensions are NEMA 56 C and fits gearbox 859.0521 and pumps with gearbox and motor configuration code **NG**.

Technical Data

Verder VA-EH25 and VA-E2H25 Electric-Operated Double Diaphragm Pump		
	US	Metric
Maximum fluid working pressure	70 psi	4.8 bar, 0.48 MPa
Air pressure operating range	20 to 80 psi	1.4 to 5.5 bar, 0.14 to 0.55 MPa
Air inlet size	3/8 in. npt(f)	
Maximum suction lift (reduced if balls don't seat well due to damaged balls or seats, lightweight balls, or extreme speed of cycling)	Wet: 29 ft Dry: 16 ft	Wet: 8.8 m Dry: 4.9 m
Maximum size pumpable solids	VA-EH25 0.42 in.	3.2 mm 10.7 mm
Ambient air temperature range for operation and storage. NOTE: Exposure to extreme low temperatures may result in damage to plastic parts.	32°F–104°F	0°C–40°C
Fluid displacement per cycle	0.10 gallons	0.38 liters
Maximum free-flow delivery	35 gpm	132.5 lpm
Maximum pump speed	280 cpm	
Fluid Inlet and Outlet Size	VA-EH25 1.5 in. sanitary flange or 40 mm DIN 11851	VA-E2H25 1.0 in. sanitary flange or 25 mm DIN 11851
Electric Motor		
	AC, A1, A2, AF, and AX	BC, B1, B2, and BX
Power	1.5 kW	1.5 kW
Pump Shaft Speed	158 rpm	81 rpm
Speed	3420 rpm (60 Hz) or 2850 rpm (50 Hz)	1800 rpm (60 Hz) or 1500 rpm (50 Hz)
Gear Ratio	18.08	8.16
Voltage	3-phase 240V / 3-Phase 415V	3-phase 230V / 3-Phase 460V
Motorless Gearbox		
NEMA (NG)		
Mounting Flange	NEMA 56 C	
Gear Ratio	18.08	
IEC (IG)		
Mounting Flange	IEC 90	
Gear Ratio	18.08	
Noise Data		
Sound Power (measured per ISO-9614-2)		
at 4.8 bar fluid pressure and 50 cpm	71 dBa	
at 2.76 bar fluid pressure and 280 cpm (full flow)	94 dBa	
Sound Pressure [tested 1 m (3.28 ft) from equipment]		

Technical Data

Verder VA-EH25 and VA-E2H25 Electric-Operated Double Diaphragm Pump		
	US	Metric
at 4.8 bar fluid pressure and 50 cpm	61 dBa	
at 2.76 bar fluid pressure and 280 cpm (full flow)	84 dBa	

Weights (typical only)

Pump Material		Motor/Gearbox					
Fluid Section	Center Section	AC/AX		NEMA NG		IEC IG	
		lb	kg	lb	kg	lb	kg
VA-EH	Aluminum	136	62	99	45	104	47
	Stainless Steel	166	75	129	58	134	61
VA-E2H	Stainless Steel	157	80	--	--	145	66

Weight		
Compressor	28 lb	13 kg
Wetted Parts		
Wetted parts include stainless steel, plus material(s) chosen for seat, ball, and diaphragm options		
Non-wetted parts		
Aluminum, coated carbon steel, bronze		
Stainless Steel, aluminum, coated carbon steel, bronze		

Fluid Temperature Range

NOTICE
Temperature limits are based on mechanical stress only. Certain chemicals will further limit the fluid temperature range. Stay within the temperature range of the most-restricted wetted component. Operating at a fluid temperature that is too high or too low for the components of your pump may cause equipment damage.

Diaphragm/Ball/Seat Material	Fluid Temperature Range	
	Fahrenheit	Celsius
Buna-N (BN)	10° to 180°F	-12° to 82°C
Polychloroprene check balls (NW)	40° to 200°F	4° to 90°C
PTFE overmolded diaphragm (TO)	40° to 180°F	4° to 82°C
PTFE check balls or two-piece PTFE/EPDM diaphragm (TF)	40° to 220°F	4° to 104°C
PTFE/Santoprene® diaphragm (TS)	40° to 180°F	4° to 82°C
Santoprene® check balls or Santoprene diaphragm (SP)	-40° to 180°F	-40° to 82°C

Customer Services/Guarantee

CUSTOMER SERVICES

If you require spare parts, please contact your local distributor, providing the following details:

- Pump Model
- Type
- Serial Number, and
- Date of First Order.

GUARANTEE

All VERDER pumps are warranted to the original user against defects in workmanship or materials under normal use (rental use excluded) for two years after purchase date. This warranty does not cover failure of parts or components due to normal wear, damage or failure which in the judgement of VERDER arises from misuse.

Parts determined by VERDER to be defective in material or workmanship will be repaired or replaced.

LIMITATION OF LIABILITY

To the extent allowable under applicable law, VERDER's liability for consequential damages is expressly disclaimed. VERDER's liability in all events is limited and shall not exceed the purchase price.

WARRANTY DISCLAIMER

VERDER has made an effort to illustrate and describe the products in the enclosed brochure accurately; however, such illustrations and descriptions are for the sole purpose of identification and do not express or imply a warranty that the products are merchantable, or fit for a particular purpose, or that the products will necessarily conform to the illustration or descriptions.

PRODUCT SUITABILITY

Many regions, states and localities have codes and regulations governing the sale, construction, installation and/or use of products for certain purposes, which may vary from those in neighboring areas. While VERDER attempts to assure that its products comply with such codes, it cannot guarantee compliance, and cannot be responsible for how the product is installed or used. Before purchasing and using a product, please review the product application as well as the national and local codes and regulations, and be sure that product, installation, and use complies with them.

Original instructions. This manual contains English.

Revision L, January 2021

Austria

Verder Austria
Eitnergasse 21/Top 8
A-1230 Wien
AUSTRIA
Tel: +43 1 86 51 074 0
Fax: +43 1 86 51 076
e-mail: office@verder.at

Belgium

Verder nv
Kontichsesteenweg 17
B-2630 Aartselaar
BELGIUM
Tel: +32 3 877 11 12
Fax: +32 3 877 05 75
e-mail: info@verder.be

China

Verder Shanghai Instruments and Equipment Co., Ltd
Building 8 Fuhai Business Park No. 299
Bisheng Road, Zhangjiang Hiteck Park
Shanghai 201204
CHINA
Tel: +86 21 33932950
Fax: +86 21 33932955
e-mail: info@verder.cn

Bulgaria

Verder Bulgaria Ltd
Vitosh department,
Manastriski Livadi Zapad
district,
110 Bulgaria Blvd., 2-nd
Floor, apt. 15-16,
1618 - Sofia
BULGARIA
Tel: 0878407370
Fax: 02 9584085
email: office@verder.bg

Czech Republic

Verder s.r.o.
Vodnanská 651/6 (vchod
Chlumecka 15)
198 00 Praha 9-Kyje
CZECH REPUBLIC
Tel: +420 261 225 386-7
Web: <http://www.verder.cz>
e-mail: info@verder.cz

France

Verder France
8 Allée Rosa Luxembourg
Immeulde Arizona
95610 Eragny sur Oise
FRANCE
Tel: +33 173 43 98 41
Fax: +33 134 64 44 50
e-mail: info@verder.fr

Germany

Verder Deutschland GmbH
Retsch-Allee 1-5
42781 Haan
GERMANY
Tel: 02104/2333-200
Fax: 02104/2333-299
e-mail: info@verder.de

Hungary

Verder Hungary Kft
Budafoke ut 187 - 189
HU-1117 Budapest
HUNGARY
Tel: 0036 1 3651140
Fax: 0036 1 3725232
e-mail: info@verder.hu

India

Verder India Pumps Pvt
Ltd.
Plot No-3B, D-1 Block,
MIDC Chinchwad,
Pune - 411019
INDIA
e-mail:
Sales@verder.co.in
www.verder.co.in

Italy

Verder Italia
Via Maestri Del lavoro, 5
02100 Vazia, Rieti
ITALY
Tel: +39 07 46 229064
e-mail: info@verder.it

Korea

Verder Korea
15-26, Beodeul-ro 1362
Paltan-myun, Hwaseong-si
Gyeonggi-do, 18578
KOREA
Tel: +82 31 355 0316
e-mail: sales@verder.kr

The Netherlands

Verder BV
Leningradweg 5
NL 9723 TP Groningen
THE NETHERLANDS
Tel: +31 50 549 59 00
Fax: +31 50 549 59 01
e-mail: info@verder.nl

Poland

Verder Polska
ul.Porcelanowa 23
PL-40 036 Katowice
POLAND
Tel: +48 32 78 15 032
Fax: +48 32 78 15 034
e-mail: verder@verder.pl

Romania

Verder România
Drumul Balta Doamnei
no 57-61
Sector 3
CP 72-117
032624 Bucuresti
ROMANIA
Tel: +40 21 335 45 92
Fax: +40 21 337 33 92
e-mail: office@verder.ro

Slovak Republik

Verder Slovakia s.r.o.
Silacska 1
SK-831 02 Bratislava
SLOVAK REPUBLIK
Tel: +421 2 4463 07 88
Fax: +421 2 4445 65 78
e-mail: info@verder.sk

South Africa

Verder SA
197 Flaming Rock Avenue
Northlands Business Park
Newmarket Street
ZA Northriding
SOUTH AFRICA
Tel: +27 11 704 7500
Fax: +27 11 704 7515
e-mail: info@verder.co.za

Switzerland

Verder Deutschland GmbH
Sales Switzerland
Retsch-Allee 1-5
D-42781 Haan
GERMANY
Tel: +41 (0)61 331 33 13
Fax: +41 (0)61 331 63 22
e-mail: info@verder.ch

United Kingdom

Verder UK Ltd.
Unit 3 California Drive
Castleford, WF10 5QH
UNITED KINGDOM
Tel: +44 (0) 1924 221 001
Fax: +44 (0) 1132 465 649
e-mail: info@verder.co.uk

United States of America

Verder Inc.
312 Corporate Parkway
Suite 101
Macon, GA 31210
USA
Tel: +1 877 783 7337
Fax: +1 478 476 9867
e-mail: sales@verder-us.com