

Verderair VA 40 (HE)

Air-Operated Diaphragm Pump

859.0345
Rev.H
EN

Polypropylene or PVDF pump for fluid transfer applications, including high viscosity materials. For professional use only.
Not for use in European explosive atmosphere locations.



Important Safety Instructions

Read all warnings and instructions in this manual. **Save these instructions.**

*Maximum Working Pressure: 8.6 bar
(0.86 MPa, 125 psi)*

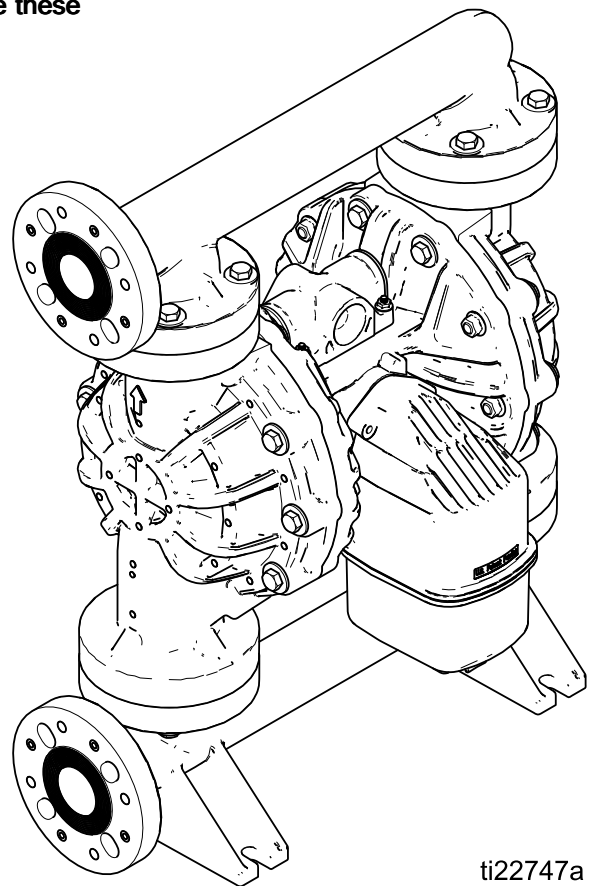

ti22747a













Contents





Warnings	3	Check Valve Repair	13
Ordering Information	6	Diaphragm and Center Section Repair	14
Related Manuals	6	Torque Instructions	18
Configuration Number Matrix	7	Parts	19
Troubleshooting	8	Seat, Check Ball, and Diaphragm Kits	29
Repair	10	Accessories	29
Pressure Relief Procedure	10	Technical Data	31
Replace Complete Air Valve	10	Customer Services/Guarantee	33
Replace Seals or Rebuild Air Valve	11		

Warnings

The following warnings are for the setup, use, grounding, maintenance, and repair of this equipment. The exclamation point symbol alerts you to a general warning and the hazard symbols refer to procedure-specific risks. When these symbols appear in the body of this manual or on warning labels, refer back to these Warnings. Product-specific hazard symbols and warnings not covered in this section may appear throughout the body of this manual where applicable.

 <h2 style="margin: 0;">WARNING</h2>	
	<p>FIRE AND EXPLOSION HAZARD</p> <p>Flammable fumes, such as solvent and paint fumes, in work area can ignite or explode. To help prevent fire and explosion:</p> <ul style="list-style-type: none"> • Use equipment only in well ventilated area. • Eliminate all ignition sources; such as pilot lights, cigarettes, portable electric lamps, and plastic drop cloths (potential static arc). • Keep work area free of debris, including solvent, rags and gasoline. • Do not plug or unplug power cords, or turn power or light switches on or off when flammable fumes are present. • Ground all equipment in the work area. See Grounding instructions. • Use only grounded hoses. • Hold gun firmly to side of grounded pail when triggering into pail. Do not use pail liners unless they are antistatic or conductive. • Stop operation immediately if static sparking occurs or you feel a shock. Do not use equipment until you identify and correct the problem. • Keep a working fire extinguisher in the work area. • Route exhaust away from all ignition sources. If diaphragm ruptures, fluid may be exhausted with air. <p>Static charge may build up on plastic parts during cleaning and could discharge and ignite flammable vapors. To help prevent fire and explosion:</p> <ul style="list-style-type: none"> • Clean plastic parts only in well ventilated area. • Do not clean with a dry cloth. • Do not operate electrostatic guns in equipment work area.
	<p>PRESSURIZED EQUIPMENT HAZARD</p> <p>Fluid from the equipment, leaks, or ruptured components can splash in the eyes or on skin and cause serious injury.</p> <ul style="list-style-type: none"> • Follow the Pressure Relief Procedure when you stop spraying/dispensing and before cleaning, checking, or servicing equipment. • Tighten all fluid connections before operating the equipment. • Check hoses, tubes, and couplings daily. Replace worn or damaged parts immediately.

 <h1 style="margin: 0;">WARNING</h1>	
  <p style="font-size: small; margin: 0;">MPa / bar / PSI</p>	<p>EQUIPMENT MISUSE HAZARD</p> <p>Misuse can cause death or serious injury.</p> <ul style="list-style-type: none"> Do not operate the unit when fatigued or under the influence of drugs or alcohol. Do not exceed the maximum working pressure or temperature rating of the lowest rated system component. See Technical Data in all equipment manuals. Use fluids and solvents that are compatible with equipment wetted parts. See Technical Data in all equipment manuals. Read fluid and solvent manufacturer's warnings. For complete information about your material, request MSDS from distributor or retailer. Do not leave the work area while equipment is energized or under pressure. Turn off all equipment and follow the Pressure Relief Procedure when equipment is not in use. Check equipment daily. Repair or replace worn or damaged parts immediately with genuine manufacturer's replacement parts only. Do not alter or modify equipment. Alterations or modifications may void agency approvals and create safety hazards. Make sure all equipment is rated and approved for the environment in which you are using it. Use equipment only for its intended purpose. Call your distributor for information. Route hoses and cables away from traffic areas, sharp edges, moving parts, and hot surfaces. Do not kink or over bend hoses or use hoses to pull equipment. Keep children and animals away from work area. Comply with all applicable safety regulations.
   <p style="font-size: small; margin: 0;">MPa / bar / PSI</p>	<p>THERMAL EXPANSION HAZARD</p> <p>Fluids subjected to heat in confined spaces, including hoses, can create a rapid rise in pressure due to the thermal expansion. Over-pressurization can result in equipment rupture and serious injury.</p> <ul style="list-style-type: none"> Open a valve to relieve the fluid expansion during heating. Replace hoses proactively at regular intervals based on your operating conditions.
 	<p>PLASTIC PARTS CLEANING SOLVENT HAZARD</p> <p>Many solvents can degrade plastic parts and cause them to fail, which could cause serious injury or property damage.</p> <ul style="list-style-type: none"> Use only compatible water-based solvents to clean plastic structural or pressure-containing parts. See Technical Data in this and all other equipment instruction manuals. Read fluid and solvent manufacturer's MSDSs and recommendations.

 WARNING	
 	<p>TOXIC FLUID OR FUMES HAZARD</p> <p>Toxic fluids or fumes can cause serious injury or death if splashed in the eyes or on skin, inhaled, or swallowed.</p> <ul style="list-style-type: none"> • Read MSDSs to know the specific hazards of the fluids you are using. • Route exhaust away from work area. If diaphragm ruptures, fluid may be exhausted into the air. • Store hazardous fluid in approved containers, and dispose of it according to applicable guidelines.
	<p>BURN HAZARD</p> <p>Equipment surfaces and fluid that's heated can become very hot during operation. To avoid severe burns:</p> <ul style="list-style-type: none"> • Do not touch hot fluid or equipment.
	<p>PERSONAL PROTECTIVE EQUIPMENT</p> <p>Wear appropriate protective equipment when in the work area to help prevent serious injury, including eye injury, hearing loss, inhalation of toxic fumes, and burns. This protective equipment includes but is not limited to:</p> <ul style="list-style-type: none"> • Protective eyewear, and hearing protection. • Respirators, protective clothing, and gloves as recommended by the fluid and solvent manufacturer.

Ordering Information

To Order a New Pump

NOTE: Do not configure and order a pump using only this manual. Work with your Verder representative or follow the steps below

1. Visit www.verderair.com. Select Verderair Series VA.
2. Click on Pump Configurator.
3. Use the configurator to specify a pump. As you work through, the configurator offers only those options that work with the pump you are building.

To Order Parts for Your Existing Pump

1. Check the identification plate (ID) for the Configuration Number of your pump.
2. Use the Configuration Number Matrix on the next page to understand which parts are described by each digit.
3. Refer to the main Parts illustration and to the Parts/Kits Quick Reference. Follow the page references for further ordering information, as needed.

Related Manuals

Manual Number	Title
859.0344	<i>Verderair</i> VA 40 Air-Operated Diaphragm Pump, Operation

Configuration Number Matrix

Check the identification plate (ID) for the Configuration Number of your pump. Use the following matrix to define the components of your pump.

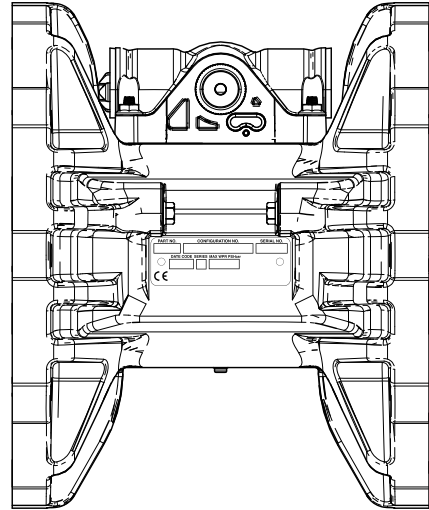
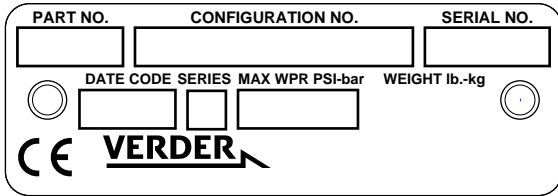

ti23919a

Sample Configuration Number: **VA40(HE)PP-SSSPSPFC00**

VA	40(HE)	P	P	SS	SP	SP	FC	00
Pump Type	Pump Size	Wetted Parts	Air Motor	Seats	Balls	Diaphragms	Manifolds	Options

Pump	Fluid Section Material		Air Section Material		Seat Material	
VA40(HE)	P	Polypropylene	P	Polypropylene	KY	PVDF
	K	PVDF			PP	Polypropylene
					SP	Santoprene
					SS	Stainless Steel

Ball Material		Diaphragm Material		Connections		Options	
SP	Santoprene	SP	Santoprene	FC	Center flange DIN/ANSI	00	Standard
TF	PTFE	TF	PTFE/Santoprene 2-Piece	FE	End flange DIN/ANSI		
VT	FKM	TO	PTFE/EPDM Overmolded				
		VT	FKM				

Troubleshooting

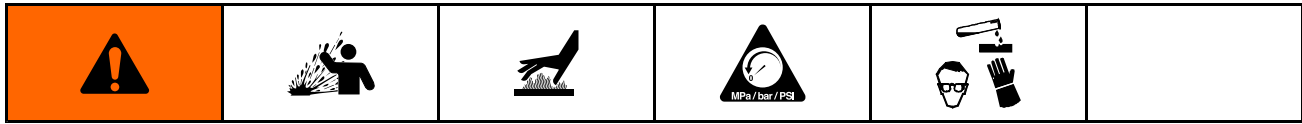

Problem	Cause	Solution
Pump cycles but will not prime.	Pump is running too fast, causing cavitation before prime.	Reduce air inlet pressure.
	Check valve ball severely worn or wedged in seat or manifold.	Replace ball and seat.
	Seat severely worn.	Replace ball and seat.
	Outlet or inlet clogged.	Unclog.
	Inlet or outlet valve closed.	Open.
	Inlet fittings or manifolds loose.	Tighten.
	Manifold o-rings damaged.	Replace o-rings.
Pump cycles at stall or fails to hold pressure at stall.	Worn check valve balls, seats, or o-rings.	Replace.
Pump will not cycle, or cycles once and stops.	Air valve is stuck or dirty.	Disassemble and clean air valve. Use filtered air.
	Check valve ball severely worn and wedged in seat or manifold.	Replace ball and seat.
	Pilot valve worn, damaged, or plugged.	Replace pilot valve.
	Air valve gasket damaged.	Replace gasket.
	Dispensing valve clogged.	Relieve pressure and clear valve.
Pump operates erratically.	Clogged suction line.	Inspect; clear.
	Sticky or leaking check valve balls.	Clean or replace..
	Diaphragm (or backup) ruptured.	Replace.
	Restricted exhaust.	Remove restriction.
	Pilot valves damaged or worn.	Replace pilot valves.
	Air valve damaged.	Replace air valve.
	Air valve gasket damaged.	Replace air valve gasket.
	Air supply erratic.	Repair air supply.
Exhaust muffler icing.	Use drier air supply.	

Problem	Cause	Solution
Air bubbles in fluid.	Suction line is loose.	Tighten.
	Diaphragm (or backup) ruptured.	Replace.
	Loose manifolds, damaged seats or o-rings.	Tighten manifold bolts or replace seats or o-rings.
	Pump cavitation.	Reduce pump speed or suction lift.
	Loose diaphragm shaft bolt.	Tighten.
Exhaust air contains fluid being pumped.	Diaphragm (or backup) ruptured.	Replace.
	Loose diaphragm shaft bolt.	Tighten or replace.
Moisture in exhaust air.	High inlet air humidity.	Use drier air supply.
Pump exhausts excessive air at stall.	Worn air valve cup or plate.	Replace cup and plate.
	Damaged air valve gasket.	Replace gasket.
	Damaged pilot valve.	Replace pilot valves.
	Worn shaft seals or bearings.	Replace shaft seals or bearings.
Pump leaks air externally.	Air valve or fluid cover screws loose.	Tighten.
	Diaphragm damaged.	Replace diaphragm.
	Air valve gasket damaged.	Replace gasket.
Pump leaks fluid externally from joints.	Loose manifold screws or fluid cover screws.	Tighten manifold screws or fluid cover screws.
	Manifold o-rings worn out.	Replace o-rings.

Repair

Pressure Relief Procedure



Follow the Pressure Relief Procedure whenever you see this symbol.

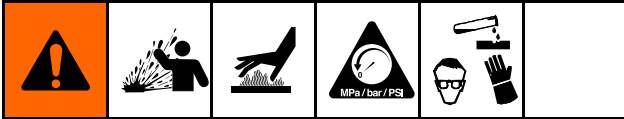

This equipment stays pressurized until pressure is relieved manually. To help prevent serious injury from pressurized fluid, such as splashing in the eyes or on skin, follow the Pressure Relief Procedure when you stop pumping and before you clean, check, or service the equipment.

1. Shut off the air supply to the pump.
2. Open the dispensing valve, if used.
3. Open the fluid drain valve to relieve fluid pressure. Have a container ready to catch the drainage.

Replace Complete Air Valve

Follow these instructions to install Air Valve Replacement Kit 859.0044.

1. Stop the pump. Follow the [Pressure Relief Procedure, page 10](#).
2. Disconnect the air line to the motor.
3. Remove nuts (104). Remove the air valve (102) and gasket (105).

4. Align the new air valve gasket (105*) on the center housing, then attach the new air valve. Follow the [Torque Instructions, page 18](#).
5. Reconnect the air line to the motor.

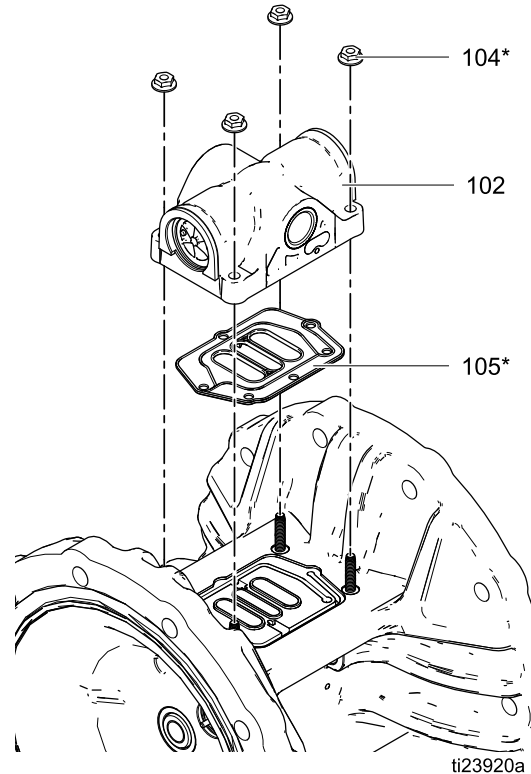

Replace Seals or Rebuild Air Valve

Follow these instructions to service the air valve with one of the available repair kits. Air Valve Seal Kit parts are marked with a †. Air Valve Repair Kit parts are marked with a ♦. Air Valve End Cap Kit parts are marked with a ‡.

Disassemble the Air Valve

1. Perform steps 1-3 under [Replace Complete Air Valve, page 10](#).
2. Use a T10 Torx screwdriver to remove two screws (209). Remove the valve plate (205), cup assembly (212-214), spring (211), and detent assembly (203).
3. Pull the cup (213) off of the base (212). Remove the o-ring (214) from the cup.
4. Remove the retaining ring (210) from each end of the air valve. Use the piston (202) to push the end cap (207) out of one end. Remove the u-cup seal (208) from the piston. Pull the piston out of the end and remove the other u-cup seal (208). Remove the other end cap (207) and the end cap o-rings (206).
5. Remove the detent cam (204) from the air valve housing (201).

Reassemble the Air Valve

NOTE: Apply lithium-based grease when instructed to grease. Order PN 819.0184.

1. Use all parts in the repair kits. Clean other parts and inspect for damage. Replace as needed.

2. Grease the detent cam (204♦) and install into housing (201).
3. Grease the u-cups (208♦†) and install on the piston with lips facing toward the center of the piston.

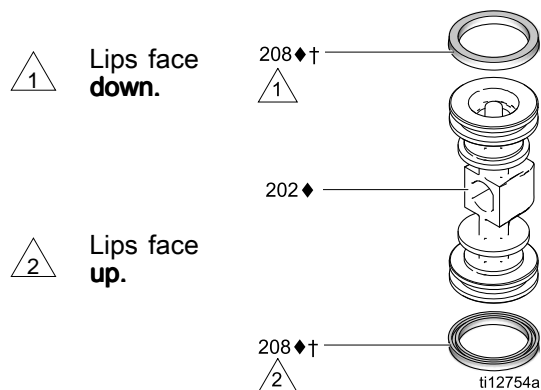

4. Grease both ends of the piston (202♦) and the housing bore. Install the piston in the housing (201), with the flat side toward the cup (213♦). Be careful not to tear u-cups (208♦†) when sliding piston into housing.
5. Grease new o-rings (206♦†‡) and install on the end caps (207‡). Install the end caps into the housing.
6. Install a retaining ring (210‡) on each end to hold end caps in place.

Repair

7. Grease and install the detent assembly (203♦) into the piston. Install the o-ring (214♦) on the cup (213♦). Apply a light film of grease to the outside surface of the o-ring and the inside mating surface of the base (212♦). Orient the end of the base that has a magnet toward the end of the cup that has the larger cutout. Engage the opposite end of the parts. Leave the end with the magnet free. Tilt the base toward the cup and fully engage the parts, using care so that the o-ring remains in place. Install the spring (211♦) onto the protrusion on the cup. Align the magnet in the base with the air inlet and install the cup assembly.

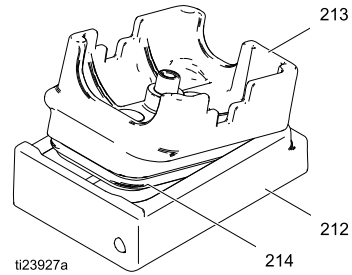

8. Grease the cup side and install the valve plate (205♦). Align the small hole in the plate with the air inlet. Tighten the screws (209♦†) to hold it in place.

- 1 Apply lithium-based grease.
- 2 U-cup lips must face piston.
- 3 Apply lithium-based grease to contact surface.
- 4 Air inlet.

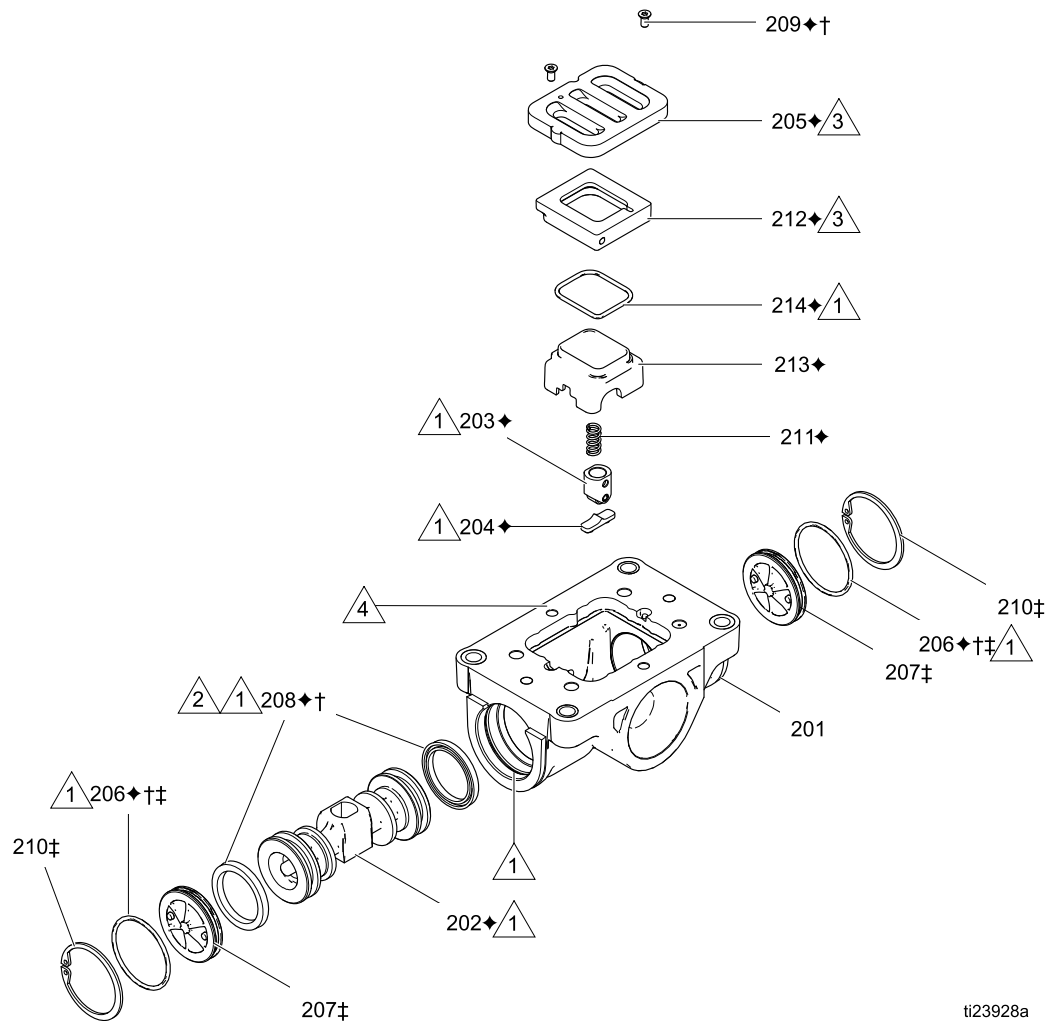

Check Valve Repair

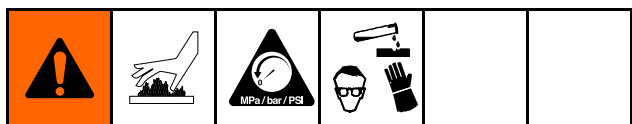

NOTE: Kits are available for new check valve balls and seats in a range of materials. See page 27 to order kits in the material(s) desired. O-ring and fastener kits also are available.

NOTE: To ensure proper seating of the check balls, always replace the seats when replacing the balls. Also, replace the o-rings every time the manifold is removed.

Disassemble the Check Valve

1. Follow the [Pressure Relief Procedure, page 10](#). Disconnect all hoses.
2. Remove the pump from its mounting.
3. **NOTE:** Use hand tools until thread-locking adhesive patch releases. Use a 17 mm (11/16 in) socket wrench to remove the manifold fasteners (5), then remove the manifold (3).
4. Remove the o-rings (9), seats (7), and balls (8).
5. Turn the pump over and remove the inlet manifold (4).
6. Remove the o-rings (9), seats (7), and balls (8).

Reassemble the Check Valve

1. Clean all parts and inspect for wear or damage. Replace parts as needed.
2. Reassemble in the reverse order, following all notes in the illustration. Put the inlet manifold on first. Be sure the ball checks (7-9) and manifolds (3, 4) are assembled **exactly** as shown. The ball must seat on the chamfered side of the seat. The arrows (A) on the fluid covers (2) **must** point toward the outlet manifold (3).

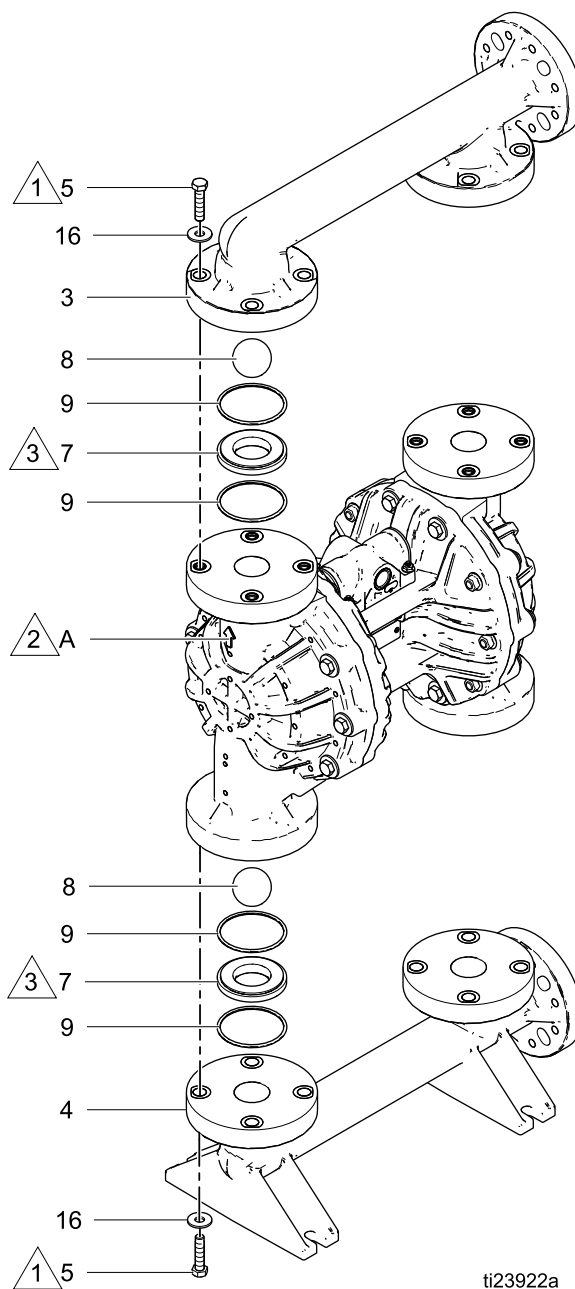
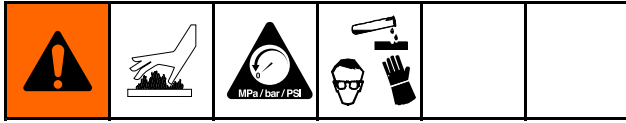

Figure 1 Check valve assembly

- 1 Torque to 21 to 25 N·m (190 to 200 in-lb). Follow torque sequence. See [Torque Instructions, page 18](#).
- 2 Arrow (A) must point toward outlet manifold
- 3 The chamfered side of the seat must face the ball.

Diaphragm and Center Section Repair



NOTE: Diaphragm kits are available in a range of materials and styles. See pages 28 – 29. A Center Rebuild Kit also is available. See page 23. Parts included in the Center Rebuild Kit are marked with an *. For best results, use all kit parts.

Disassemble the Diaphragm and Center Section

1. Follow the [Pressure Relief Procedure, page 10](#).
2. Remove the manifolds and disassemble the ball check valves as explained in [Check Valve Repair, page 13](#).

NOTE: You may wish to remove the inner fluid cover bolts (5) as you remove each manifold, for convenience.

3. **Overmolded Diaphragms (TO models)**
 - a. Orient the pump so one of the fluid covers (2) faces up. Use a 17 mm socket wrench to remove the fluid cover bolts (5, 6), then pull the fluid cover up off the pump.
 - b. The exposed diaphragm (12) will screw off by hand. The shaft will either release and come off with this diaphragm, or remain attached to the other diaphragm. If the diaphragm shaft bolt (14) remains attached to the shaft (108), remove it. Remove the air side diaphragm plate (11) and washer (17).
 - c. Turn the pump over and remove the other fluid cover. Remove the diaphragm (and the shaft, if necessary).
 - d. If the shaft is still attached to either diaphragm, grasp the diaphragm firmly and use a wrench on the flats of the shaft to remove. Also remove the air side diaphragm plate (11) and washer (17). Continue with Step 5.

4. All Other Diaphragms

- a. Orient the pump so one of the fluid covers faces up. Use a 17 mm socket wrench to remove the fluid cover screws (5, 6), then pull the fluid cover (2) up off the pump. Turn the pump over and remove the other fluid cover.
 - b. Hold the hex of one fluid side diaphragm plate (15) with a 38 mm (1-1/2 in) socket or box end wrench. Use another wrench (same size) on the hex of the other plate to remove. Then remove all parts of each diaphragm assembly.
5. Inspect the diaphragm shaft (108) for wear or scratches. If it is damaged, inspect the bearings (107) in place. If they are damaged, use a bearing puller to remove them.

NOTE: Do not remove undamaged bearings.

6. Use an o-ring pick to remove the u-cup packings (106) from the center housing. Bearings (107) can remain in place.
7. If necessary, use a socket wrench to remove the pilot valves (111).
8. Remove the pilot valve cartridges only if necessary due to a known or suspected problem. **After removing pilot valves**, use a hex to remove the cartridges (109), then remove cartridge o-rings (110). If stripped, use two screwdrivers to screw out the cartridge.

NOTE: Do not remove undamaged pilot valve cartridges.

Reassemble the Diaphragm and Center Section

Follow all notes in the illustration. These notes contain **important** information.

NOTE: Apply lithium-based grease whenever instructed to grease. Order PN 819.0184.

1. Clean all parts and inspect for wear or damage. Replace parts as needed.
2. If removed, grease and install the new pilot valve cartridges (109), cartridge o-rings (110), and retaining rings (113).

NOTE: Cartridges (109) *must* be installed before pilot valves (111).

3. Grease and install the pilot valves (111). Torque to 2.3-2.8 N•m (20-25 in.-lb), at 110 rpm. Do not over-torque.
4. Grease and install the diaphragm shaft u-cup packings (106) so the lips face **out** of the housing.
5. If removed, insert the new bearings (107) into the center housing. Use a press or a block and rubber mallet to press-fit the bearing so it is flat with the surface of the center housing.

6. Overmolded Diaphragms (TO)

- a. Clamp the shaft flats in a vise.
- b. If diaphragm setscrew comes loose or is replaced, apply permanent (red) thread locker to diaphragm side threads. Screw into diaphragm until tight.
- c. Assemble the air side plate (11) and washer (17) onto the diaphragm. The rounded side of the plate must face the diaphragm.
- d. Apply primer and medium-strength (blue) thread locker to the threads of the diaphragm assembly. Screw the assembly into the shaft as tight as possible by hand.
- e. Grease the shaft u-cups (106*) and the length and ends of the diaphragm shaft (108*). Slide the shaft into the housing.
- f. Reattach one fluid cover (3). Arrow (A) must point toward the air valve. See [Torque Instructions, page 18](#).
- g. Repeat Steps b-d for the other diaphragm assembly and install on the exposed end of the shaft.
- h. Tighten by hand as much as possible. Go to Step 8.

7. All Other Diaphragms

- a. Assemble the diaphragm (12), the backup diaphragm (13, if present), the air side diaphragm plate (11), and the washer (17) on the fluid side plate (10) exactly as shown.
- b. Apply primer and medium-strength (blue) thread locker to the threads of the screw on the fluid side plate. Screw the assembly into the shaft hand-tight.
- c. Grease the shaft u-cups (106*) and the length and ends of the diaphragm shaft (108*). Slide the shaft into the housing.
- d. Repeat for the other diaphragm assembly and install on the exposed end of the shaft.
- e. Hold one of the plates with a wrench, and torque the other plate to 88–95 N•m (65–70 ft-lb) at 100 rpm maximum. Do not over-torque.
- f. Reattach one fluid cover (3). Arrow (A) must point toward the air valve. See [Torque Instructions, page 18](#).

SP and VT Models

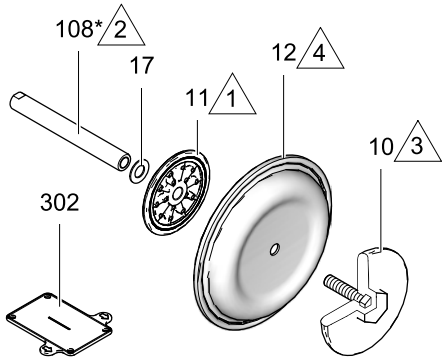

ti24028a

TO Models

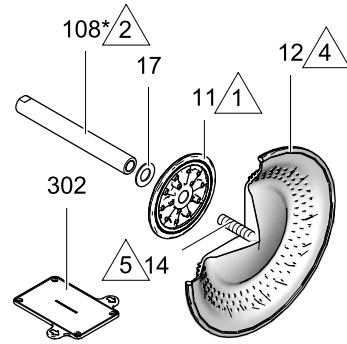

ti24029a

TF Models

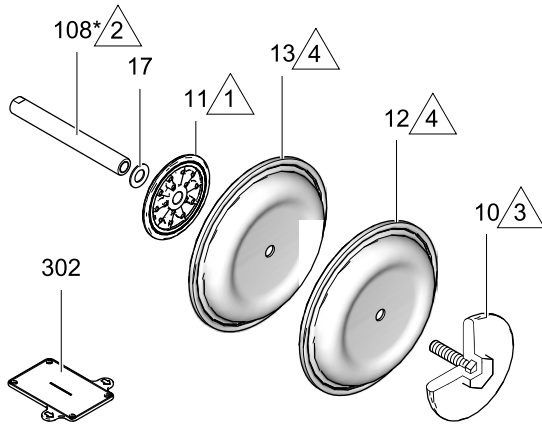

ti24027a

- 1
- 2
- 3
- 4
- 5
- 6
- 7
- 8

Rounded side faces diaphragm

Apply lithium based grease.

Apply primer and medium-strength (blue) thread locker. Torque to 88–95 N•m (65–70 ft-lb).

AIR SIDE markings on diaphragm must face center housing.

If screw comes loose or is replaced, apply permanent (red) thread locker to diaphragm side threads. Apply primer and medium-strength (blue) thread locker to shaft side threads.

Lips must face out of housing.

Cartridges (109) must be installed before pilot valves (111).

Torque to 2–3 N•m (20-25 in.-lb).

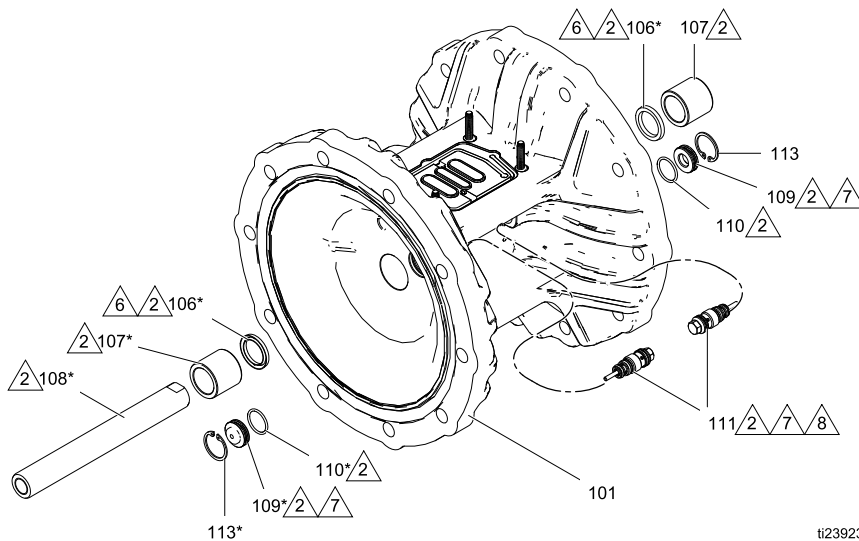

ti23923a

8. To ensure proper seating and extend diaphragm life, apply air pressure to the pump prior to attaching the second fluid cover.
 - a. Place the supplied tool (302) where the air valve gasket (105) normally goes. Arrows (A) must face toward the fluid cover that is already attached.

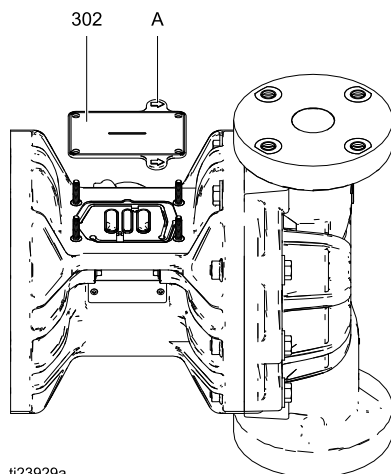

ti23929a

Figure 2 Fluid cover tool

- b. Reattach the air valve.
- c. Supply a minimum of 1.4 bar (0.14 MPa, 20 psi) air pressure to the air valve. Shop air may be used. The diaphragm will shift so the second fluid cover will seat properly. Keep air pressure on until the second fluid cover is attached.
- d. Attach the second fluid cover (3). See [Torque Instructions, page 18](#).
- e. Remove the air valve and the tool (302), replace the gasket (105), and reattach the air valve. See [Torque Instructions, page 18](#).

NOTE: If you are replacing the diaphragms but not the air valve, you must remove the air valve and gasket, put the tool in place of the gasket, and put the air valve back on to get the air pressure needed for proper installation of the second fluid cover. Remember to remove the tool and replace the gasket when finished.

- f. Reassemble the ball check valves and manifolds as explained in [Check Valve Repair, page 13](#).

Torque Instructions

If fluid cover or manifold fasteners have been loosened, it is important to torque them using the following procedure to improve sealing.

NOTE: Fluid cover and manifold fasteners have a thread-locking adhesive patch applied to the threads. If this patch is excessively worn, the fasteners may loosen during operation. Replace screws with new ones or apply medium-strength (blue) Loctite or equivalent to the threads.

NOTE: Always completely torque fluid covers before torquing manifolds.

1. Start all fluid cover screws a few turns. Then, turn down each screw just until head contacts cover.
2. Turn each screw by 1/2 turn or less working in a crisscross pattern to specified torque.
3. Repeat for manifolds.

Fluid cover and manifold fasteners: 21 to 25 Nm (190 to 220 in-lb)

4. Retorque the air valve fasteners in a crisscross pattern to the specified torque.

Air valve fasteners: 5 to 6 Nm (45 to 55 in-lb)

5. Retorque the pilot valves to the specified torque. **Do not overtorque.**

Pilot valves: 2–3 Nm (20 to 25 in-lb)

Fluid Cover Screws

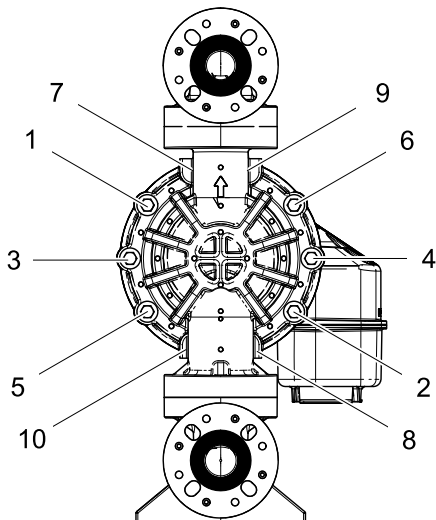

ti22752a

Inlet and Outlet Manifold Screws

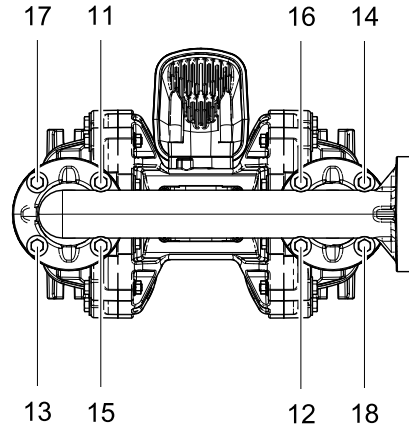

ti22753a

Air Valve Screws and Pilot Valves

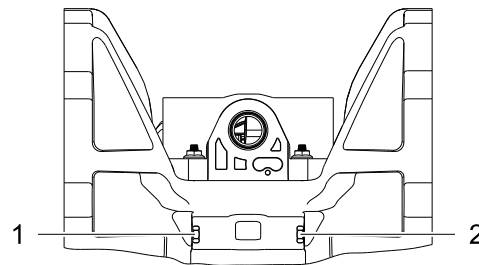
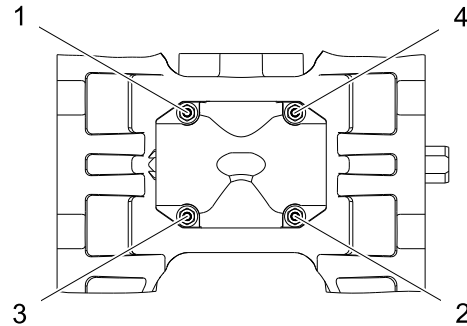

ti21912a

Parts

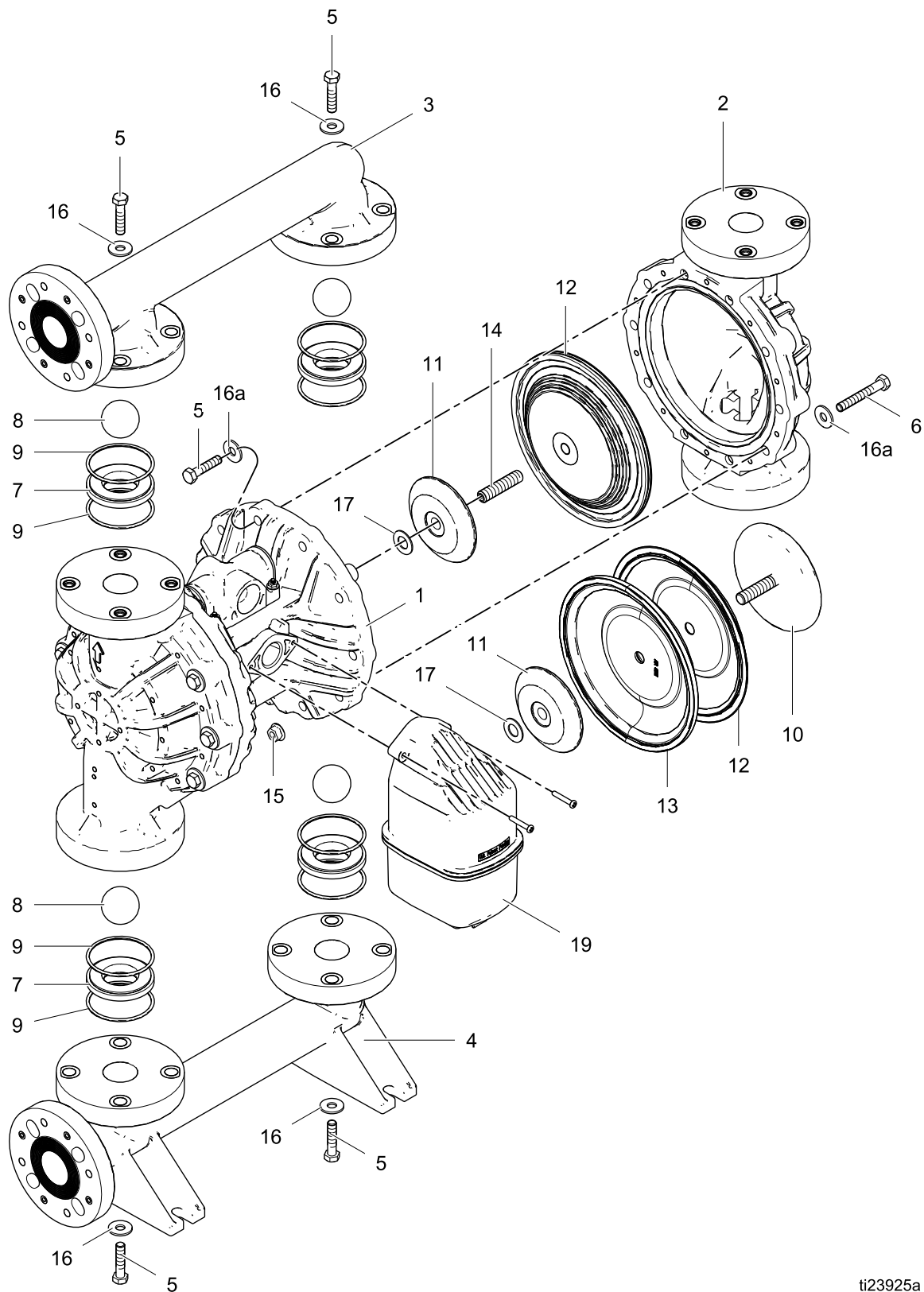

ti23925a

Parts/Kits Quick Reference

Use this table as a quick reference for parts/kits. Go to the pages indicated in the table for a full description of kit contents.

Ref.	Part/Kit	Description	Qty.
1	859.0403	Center Housing Kit; Polypropylene	1
102	859.0044	Air Valve; <i>see page 26.</i>	1
2		Fluid Cover Kits; <i>see page 22</i>	2
	859.0318	Polypropylene	
	859.0324	PVDF	
3		Outlet Manifold Kits; <i>see page 22</i>	1
	859.0339	Polypropylene, center flange	
	859.0322	Polypropylene, end flange	
	859.0341	PVDF, end flange	
4		Inlet Manifold Kits; <i>see page 22</i>	1
	859.0340	Polypropylene, center flange	
	859.0323	Polypropylene, end flange	
	859.0342	PVDF, end flange	
5	859.0321	Manifold Fastener Kit; <i>see page 22</i>	2
6	859.0319	Fluid Cover Fastener Kit; <i>see page 22</i>	2
7		Seats; 4-pack; <i>see page 27</i>	1
	859.0332	Polypropylene	
	859.0331	PVDF	
	859.0333	Santoprene	
	859.0334	Stainless Steel	
8		BALLS, valve, check; 4-pack; <i>see page 27</i>	1
	859.0337	FKM	
	859.0335	PTFE	
	859.0336	Santoprene	
9	859.0320	O-RING, seat; 8-pack, <i>see page 27.</i>	1

Ref.	Part/Kit	Description	Qty.
10		Fluid Side Diaphragm Plate; <i>see pages 29 & 30</i>	2
	859.0329	Polypropylene	
	859.0330	PVDF	
11	859.0338	Air Side Diaphragm Plate; includes washer (Ref. 17); <i>see pages 29 & 30</i>	2
12		Diaphragm Kits; 2-pack, <i>see pages 28-30</i>	1
	859.0327	FKM Fluoroelastomer, 1-piece, bolt-through	
	859.0326	Santoprene, 1-piece, bolt-through	
	859.0325	PTFE/EPDM Overmolded; includes screw (Ref. 14)	
	859.0328	PTFE/Santoprene, 2-Piece, bolt-through; includes backup diaphragm (Ref. 13)	
13	---	DIAPHRAGM, backup, Santoprene	1
14	---	SCREW, set; included with TO diaphragms (Ref. 12).	
15	---	NUT, included with Ref. 6	16
16	---	WASHER, 4 mm THK	16
16a	---	WASHER, 2.3 mm THK	20
17	---	WASHER, included with Ref. 11	1
18	819.4313▲	LABEL, warning	1
19	859.0252	Muffler; includes o-ring and mounting hardware	1
20	859.0352▲	TAG, torque instructions	1
21	859.0353▲	LABEL, multilingual warning	1

▲ Replacement Warning labels, signs, tags, and cards are available at no cost.

Fluid Section

Sample Configuration Number

Pump Size	Fluid Section	Air Section	Seats	Balls	Diaphragms	Manifolds	Options
VA40(HE)	P	P	SS	SP	SP	FC	00

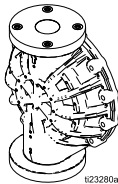
Fluid Cover Kits			
P	859.0318	K	859.0324
			

Kits include 1 fluid cover (2)

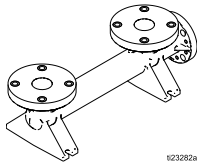
End Inlet Manifold Kits			
P...FE	859.0323	K...FE	859.0342
			

Kits include 1 manifold (4), 8 washers (16)

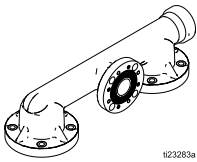
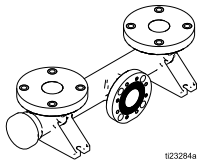
Center Manifold Kits		
P...FC	Outlet (3)	Inlet (4)
	859.0339	859.0340
		

Kits include 1 manifold, 8 washers (16)

Fluid Cover Fastener Kits	
All Models	859.0319

Kit includes:

- 6 bolts (6), hex head, stainless steel, M10 x 1.5 x 70 mm (2.76 in.)
- 4 bolts (5), hex head, stainless steel, M10 x 1.5 x 45 mm (1.77 in.)
- 12 washers (16a)
- 6 nuts (15), hex, flange, M10

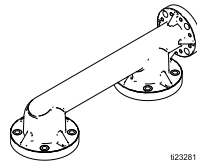
End Outlet Manifold Kits			
P...FE	859.0322	K...FE	859.0341
			

Kits include 1 manifold (3), 8 washers (16)

Manifold Fastener Kits	
All Models	859.0321

Kit includes:

- 8 bolts (5), hex head, stainless steel, M10 x 1.5 x 45 mm (1.77 in.)
- 8 washers (16)

Air Section

Sample Configuration Number

Pump Size	Fluid Section	Air Section	Seats	Balls	Diaphragms	Manifolds	Options
VA40(HE)	P	P	SS	SP	SP	FC	00

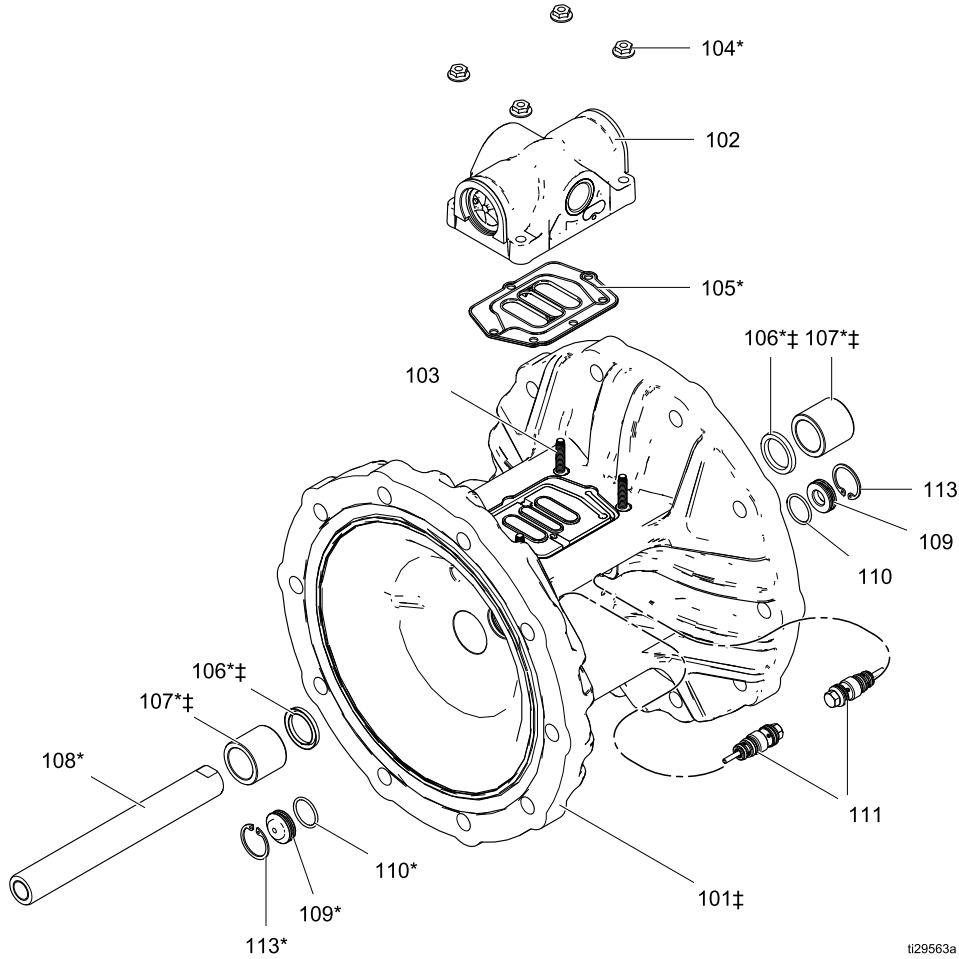

Ref	Description	Qty	Ref	Description	Qty
101‡	HOUSING, center, not sold separately	1	108*	SHAFT, center	1
102	VALVE, air, <i>see page 26.</i>	1	109*	CARTRIDGE, pilot receiver	2
103	SCREW, hi-lo stud	4	110*	O-RING, Buna-N	2
104*	NUT, hex, flange, serrated	4	111*	VALVE, pilot, assembly	2
105*	GASKET, air valve	1	112*	LUBRICANT	1
106*‡	U-CUP, center shaft	2	113*	RING, retaining	2
107*‡	BEARING, shaft	2			

* Included in the Air Section Rebuild Kit.

‡ Included in the Center Housing Kit.

Sample Configuration Number

Pump Size	Fluid Section	Air Section	Seats	Balls	Diaphragms	Manifolds	Options
VA40(HE)	P	P	SS	SP	SP	FC	00

Air Section Rebuild Kits (*)	
P with 2-Piece diaphragms (TF) or standard diaphragms (SP, VT)	859.0314
P with overmolded diaphragms (TO)	859.0315

Kits include:

- 1 center shaft (108)
- 4 hex nuts, serrated (104)
- 2 center shaft bearings (107)
- 2 center shaft u-cups (106)
- 1 air valve gasket (105)
- 8 seat o-rings (9)
- 2 pilot valves (111)
- 2 pilot valve receiver cartridges (109)
- 2 retaining rings (113)
- 2 receiver cartridge o-rings (110)
- 1 grease packet (112)

Pilot Valve Assembly Kit	
All models	819.9761

Kit includes:

- 2 pilot valves (111)
- 2 pilot valve receiver cartridges (109)
- 2 receiver cartridge o-rings (110)
- 1 grease packet (112)
- 2 retaining rings (113)

Center Shaft Kits (*)	
P with 2-Piece diaphragms (TF) or standard diaphragms (SP, VT)	859.0316
P with overmolded diaphragms (TO)	859.0317

Kits include:

- 2 center shaft u-cups (106)
- 1 center shaft (108)
- 2 center shaft bearings (107)
- 1 grease packet (112)

Center Shaft Bearing Kit	
All models	859.0037

Kit includes:

- 2 center shaft u-cups (106)
- 2 center shaft bearings (107)
- 1 grease packet (112)

Center Housing Kit	
All models	859.0403

Kit includes:

- 2 center shaft u-cups (106)
- 2 center shaft bearings (107)
- 1 center housing (101)

Air Valve

Sample Configuration Number

Pump Size	Fluid Section	Air Section	Seats	Balls	Diaphragms	Manifolds	Options
VA40(HE)	P	P	SS	SP	SP	FC	00

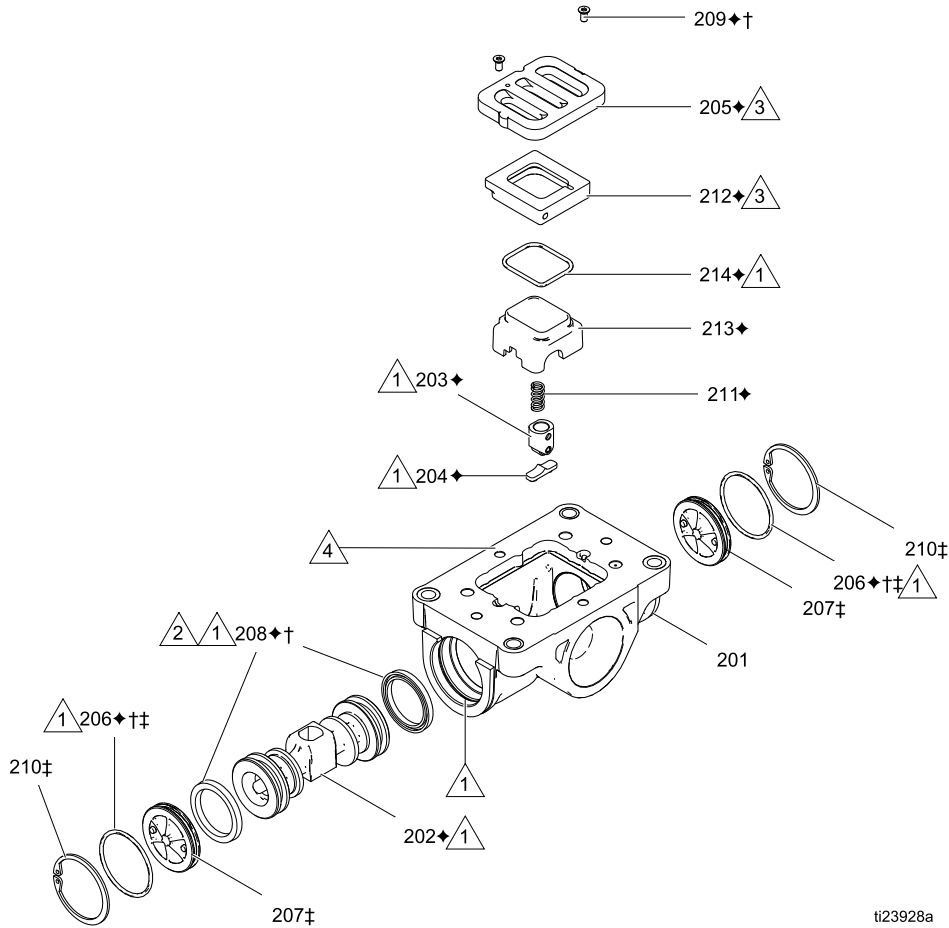

Ref	Description	Qty	Ref	Description	Qty
201	HOUSING, not sold separately	1	208◆†	U-CUP	2
202◆	PISTON	1	209◆†	SCREW, #4, thread forming	2
203◆	PISTON ASSEMBLY, detent	1	210‡	RETAINING RING	2
204◆	CAM, detent	1	211◆	SPRING, detent	1
205◆	PLATE, air valve	1	212◆	BASE, cup	1
206◆†‡	O-RING	2	213◆	CUP	1
207‡	CAP, end	2	214◆	O-RING, cup	1

◆ Parts included in Air Valve Repair Kit.

‡ Parts included in Air Valve End Cap Kit.

† Parts included in Air Valve Seals Kit.

Sample Configuration Number

Pump Size	Fluid Section	Air Section	Seats	Balls	Diaphragms	Manifolds	Options
VA40(HE)	P	P	SS	SP	SP	FC	00

† Air Valve Seals Kit	
All models	859.0041

Kit includes:

- 2 end cap o-rings (206)
- 2 piston u-cups (208)
- 2 screws, M3, shorter (not used)
- 2 screws, #4, longer (209)
- 1 air valve gasket (105)
- 1 grease packet (112)
- 1 solenoid release button o-ring (not shown, not used)

◆ Air Valve Repair Kit	
All models	859.0040

Kit includes:

- 1 air valve piston (202)
- 1 detent piston assembly (203)
- 1 detent cam (204)
- 1 air valve plate (205)
- 2 end cap o-rings (206)
- 2 piston u-cups (208)
- 2 screws, M3, shorter (not used)
- 2 screws, #4, longer (209)
- 1 detent spring (211)
- 1 air cup base (212)
- 1 air cup (213)
- 1 air cup o-ring (214)
- 1 solenoid release button o-ring (not shown, not used)
- 1 air valve gasket (105)
- 1 grease packet (112)

Air Valve Replacement Kit	
All models	859.0044

Kits include:

- 1 air valve assembly (102)
- 1 air valve gasket (105)
- 4 hex nuts (104)

‡ Air Valve End Cap Kit	
All models	859.0073

Kit includes:

- 2 end caps (207)
- 2 retaining rings (210)
- 2 o-rings (206)
- 1 grease packet (112)

Seats and Check Balls

Sample Configuration Number

Pump Size	Fluid Section	Air Section	Seats	Balls	Diaphragms	Manifolds	Options
VA40(HE)	P	P	SS	SP	SP	FC	00

Valve Seat Kits				
Seat Material	Ref. No.	Part/Kit	Description	Qty.
PP	7	859.0332	VA40(HE) PP,--,--,--	1
	9	859.0320	VA40(HE) --,--,--,TF	1
		859.0356	VA40(HE) --,--,--,VT-TF	1
		859.0357	VA40(HE) --,--,--,VT75	1
SS	7	859.0334	VA40(HE) SS,--,--,--	1
	9	859.0320	VA40(HE) --,--,--,TF	1
		859.0356	VA40(HE) --,--,--,VT-TF	1
		859.0357	VA40(HE) --,--,--,VT75	1
SP	7	859.0333	VA40(HE) SP,--,--,--	1
	9	859.0320	VA40(HE) --,--,--,TF	1
		859.0356	VA40(HE) --,--,--,VT-TF	1
		859.0357	VA40(HE) --,--,--,VT75	1
KY	7	859.0331	VA40(HE) KY,--,--,--	1
	9	859.0320	VA40(HE) --,--,--,TF	1
		859.0356	VA40(HE) --,--,--,VT-TF	1
		859.0357	VA40(HE) --,--,--,VT75	1

Check Ball Kits				
Ball Material	Ref. No.	Part/Kit	Description	Qty.
SP	8	859.0336	VA40(HE) --,SP,--,--	1
TF	8	859.0335	VA40(HE) --,TF,--,--	1
VT	8	859.0337	VA40(HE) --,VT,--,--	1

Diaphragms

Sample Configuration Number

Pump Size	Fluid Section	Air Section	Seats	Balls	Diaphragms	Manifolds	Options
VA40(HE)	P	P	SS	SP	SP	FC	00

1-Piece Bolt-through Diaphragm Kits				
Diaphragm Material	Ref. No.	Part/Kit	Description	Qty
SP	12	859.0326	VA40(HE) --,--,SP,--	1
	13	Not required		
VT	12	859.0327	VA40(HE) --,--,VT,--	1
	13	Not required		

Overmolded Diaphragm Kit				
Diaphragm Material	Ref. No.	Part/Kit	Description	Qty
TO	12	859.0325	VA40(HE) --,--,TO,--	1
	13	Not required		

Kits include:

- 2 diaphragms (12), material indicated in table
- 1 diaphragm install tool (302)
- 1 packet anaerobic adhesive

NOTE: Fluid and Air plates are sold separately. The shaft is part of the Center Section Rebuild Kit (859.0314) or the Center Shaft Kit (859.0316). See [Air Section](#).

Kits include:

- 2 overmolded diaphragms (12), material indicated in table.
- 2 diaphragm set screws, stainless steel (14)
- 1 diaphragm install tool (302)
- 1 packet anaerobic adhesive

NOTE: Air plates are sold separately. The shaft is part of the Center Section Rebuild Kit (859.0267) or the Center Shaft Kit (859.0269). See [Air Section](#).

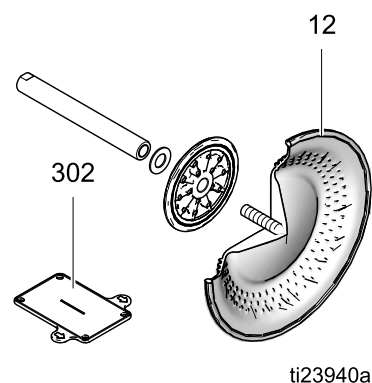
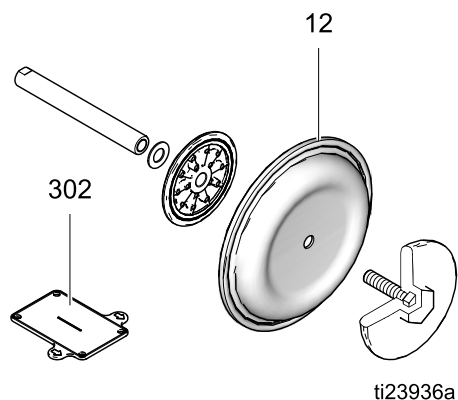

Parts

Sample Configuration Number

Pump Size	Fluid Section	Air Section	Seats	Balls	Diaphragms	Manifolds	Options
VA40(HE)	P	P	SS	SP	SP	FC	00

2-Piece Bolt-through Diaphragm Kit				
Diaphragm Material	Ref. No.	Part/Kit	Description	Qty
TF	12	859.0328	VA40(HE) --,--,TF,--	1
	13	Included in above kit		

Fluid Plate Kits	
P	859.0329
K	859.0330

Kits include:

- 1 fluid side diaphragm plate (10), includes shaft bolt
- 1 packet anaerobic adhesive

Air Plate Kits	
All Models	859.0338

Kits include:

- 2 diaphragms (12), PTFE
- 2 backup diaphragms (13), Santoprene
- 1 diaphragm install tool (302)
- 1 packet anaerobic adhesive

Kits include:

- 1 air side plate (11)
- 1 washer (17)

NOTE: Fluid and Air plates are sold separately. The shaft is part of the Center Section Rebuild Kit (859.0314) or the Center Shaft Kit (859.0316). See [Air Section](#).

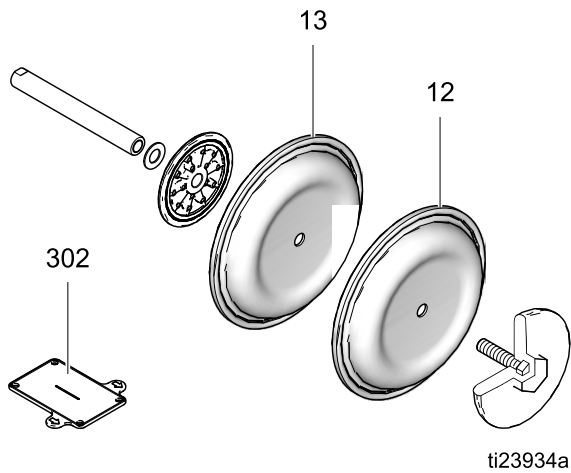

Seat, Check Ball, and Diaphragm Kits

Sample Configuration Number

Pump Size	Fluid Section	Air Section	Seats	Balls	Diaphragms	Manifolds	Options
VA40(HE)	P	P	SS	SP	SP	FC	00

Kit	Parts	Qty
859.0434 (PP, TF, TF)	SEAT, polypropylene	4
	BALL, PTFE	4
	O-RING, PTFE	8
	DIAPHRAGM, PTFE	2
	DIAPHRAGM, Santoprene	2
	TOOL, diaphragm install	1
	ADHESIVE, anaerobic	1
859.0435 (PP, SP, SP)	SEAT, polypropylene	4
	BALL, Santoprene	4
	O-RING, PTFE	8
	DIAPHRAGM, Santoprene	2
	TOOL, diaphragm install	1
	ADHESIVE, anaerobic	1
859.0436 (SP, SP, SP)	SEAT, Santoprene	4
	BALL, Santoprene	4
	O-RING, PTFE	8
	DIAPHRAGM, Santoprene	2
	TOOL, diaphragm install	1
	ADHESIVE, anaerobic	1
859.0437 (KY, TF, TF)	SEAT, PVDF	4
	BALL, PTFE	4
	O-RING, PTFE	8
	DIAPHRAGM, PTFE	2
	DIAPHRAGM, Santoprene	2
	TOOL, diaphragm install	1
	ADHESIVE, anaerobic	1

Kit	Parts	Qty	
859.0438 (KY, TF, TO)	SEAT, PVDF	4	
	BALL, PTFE	4	
	O-RING, PTFE	8	
	DIAPHRAGM, PTFE Overmolded	2	
	SCREW, set	2	
	TOOL, diaphragm install	1	
	ADHESIVE, anaerobic	1	
	ADHESIVE, sealant	1	
	859.0439 (PP, TF, TO)	SEAT, Polypropylene	4
		BALL, PTFE	4
O-RING, PTFE		8	
DIAPHRAGM, PTFE Overmolded		2	
SCREW, set		2	
TOOL, diaphragm install		1	
ADHESIVE, anaerobic		1	
ADHESIVE, sealant		1	
859.0440 (KY, VT, VT)	SEAT, PVDF	4	
	BALL, FKM Fluoroelastomer	4	
	O-RING, PTFE	8	
	DIAPHRAGM, FKM Fluoroelastomer	2	
	TOOL, diaphragm install	1	
	ADHESIVE, anaerobic	1	
859.0441 (PP, VT, VT)	SEAT, Polypropylene	4	
	BALL, FKM Fluoroelastomer	4	
	O-RING, PTFE	8	
	DIAPHRAGM, FKM Fluoroelastomer	2	
	TOOL, diaphragm install	1	
	ADHESIVE, anaerobic	1	

Accessories

Muffler 819.6591

Legacy or remote exhaust muffler option.

Notes

Technical Data

Verderair VA 40 (HE) Diaphragm Pump		
	US	Metric
Maximum fluid working pressure	125 psi	0.86 MPa, 8.6 bar
Air pressure operating range	20 to 125 psi	0.14 to 0.86 MPa, 1.4 to 8.6 bar
Air inlet size	1/2 in. (npt(f))	
Air exhaust size	1 in.	
Fluid inlet and outlet size (ANSI/DIN flange)	1.5 in	38 mm
Maximum suction lift (reduced if balls don't seat well due to damaged balls or seats, lightweight balls, or extreme speed of cycling)	Wet: 31 ft Dry: 16 ft	Wet: 9.4 m Dry: 4.9 m
Maximum size pumpable solids	1/4 in.	6.3 mm
Minimum ambient air temperature for operation and storage. NOTE: Exposure to extreme low temperatures may result in damage to plastic parts.	32° F	0° C
Air Consumption	43 scfm at 70 psi, 60 gpm	1.2 m ³ /min at 0.48 MPa, 4.8 bar, 227 lpm
Maximum Air Consumption	85 scfm	2.4 m ³ /min
Noise (dBa) Sound power measured per ISO-9614-2. Sound pressure was tested 3.28 ft (1 m) from equipment.		
Sound Power	90.9 at 70 psi and 50 cpm 102.1 at 100 psi and full flow	90.9 at 4.8 bar and 50 cpm 102.1 at 7.0 bar and full flow
Sound Pressure	83.6 at 70 psi and 50 cpm 95.7 at 100 psi and full flow	83.6 at 4.8 bar and 50 cpm 95.7 at 7.0 bar and full flow
Fluid flow per cycle		
1-piece bolt-through diaphragms	0.63 gallons	2.4 liters
2-piece bolt-through diaphragms	0.66 gallons	2.5 liters
Overmolded diaphragms	0.59 gallons	2.3 liters
Maximum free-flow delivery		
1-piece bolt-through diaphragms	122 gpm	462 lpm
2-piece bolt-through diaphragms	120 gpm	454 lpm
Overmolded diaphragms	115 gpm	435 lpm

Technical Data

Maximum pump speed		
1-piece bolt-through diaphragms	192 cycles per minute	
2-piece bolt-through diaphragms	183 cycles per minute	
Overmolded diaphragms	195 cycles per minute	
Weight		
Polypropylene	57 lb	25.9 kg
PVDF	74 lb	33.6 kg
Wetted Parts		
Wetted parts include material(s) chosen for seat, ball, and diaphragm options, plus the pump's material of construction: Polypropylene or PVDF		
Non-wetted external parts	stainless steel, polypropylene	

Fluid Temperature Range

Diaphragm/Ball/Seat Material	US		Metric	
	Polypropylene Pump	PVDF Pump	Polypropylene Pump	PVDF Pump
FKM Fluoroelastomer	32° to 150°	32° to 225°	0° to 66°	0° to 107°
Polypropylene	32° to 150°	32° to 150°	0° to 66°	0° to 66°
PTFE overmolded diaphragm	40° to 150°	40° to 180°	4° to 66°	4° to 82°
PTFE check balls	40° to 150°	40° to 220°	4° to 66°	4° to 104°
PVDF	32° to 150°	32° to 225°	0° to 66°	0° to 107°
Santoprene	32° to 150°	32° to 180°	0° to 66°	0° to 82°
2-piece PTFE/Santoprene diaphragm	40° to 150°	40° to 180°	4° to 66°	4° to 82°

Customer Services/Guarantee

CUSTOMER SERVICES

If you require spare parts, please contact your local distributor, providing the following details:

- Pump Model
- Type
- Serial Number, and
- Date of First Order.

GUARANTEE

All VERDER pumps are warranted to the original user against defects in workmanship or materials under normal use (rental use excluded) for two years after purchase date. This warranty does not cover failure of parts or components due to normal wear, damage or failure which in the judgement of VERDER arises from misuse.

Parts determined by VERDER to be defective in material or workmanship will be repaired or replaced.

LIMITATION OF LIABILITY

To the extent allowable under applicable law, VERDER's liability for consequential damages is expressly disclaimed. VERDER's liability in all events is limited and shall not exceed the purchase price.

WARRANTY DISCLAIMER

VERDER has made an effort to illustrate and describe the products in the enclosed brochure accurately; however, such illustrations and descriptions are for the sole purpose of identification and do not express or imply a warranty that the products are merchantable, or fit for a particular purpose, or that the products will necessarily conform to the illustration or descriptions.

PRODUCT SUITABILITY

Many regions, states and localities have codes and regulations governing the sale, construction, installation and/or use of products for certain purposes, which may vary from those in neighboring areas. While VERDER attempts to assure that its products comply with such codes, it cannot guarantee compliance, and cannot be responsible for how the product is installed or used. Before purchasing and using a product, please review the product application as well as the national and local codes and regulations, and be sure that product, installation, and use complies with them.

Original instructions. This manual contains English.

Revision G, December 2019

Austria

Verder Austria
Eitnergasse 21/Top 8
A-1230 Wien
AUSTRIA
Tel: +43 1 86 51 074 0
Fax: +43 1 86 51 076
e-mail: office@verder.at

Belgium

Verder nv
Kontichsesteenweg 17
B-2630 Aartselaar
BELGIUM
Tel: +32 3 877 11 12
Fax: +32 3 877 05 75
e-mail: info@verder.be

China

Verder Shanghai Instruments and Equipment Co., Ltd
Building 8 Fuhai Business Park No. 299
Bisheng Road, Zhangjiang Hiteck Park
Shanghai 201204
CHINA
Tel: +86 21 33932950
Fax: +86 21 33932955
e-mail: info@verder.cn

Bulgaria

Verder Bulgaria Ltd
Vitosh department,
Manastriski Livadi Zapad
district,
110 Bulgaria Blvd., 2-nd
Floor, apt. 15-16,
1618 - Sofia
BULGARIA
Tel: 0878407370
Fax: 02 9584085
email: office@verder.bg

Czech Republic

Verder s.r.o.
Vodnanská 651/6 (vchod
Chlumecka 15)
198 00 Praha 9-Kyje
CZECH REPUBLIC
Tel: +420 261 225 386-7
Web: <http://www.verder.cz>
e-mail: info@verder.cz

France

Verder France
8 Allée Rosa Luxembourg
Immeulde Arizona
95610 Eragny sur Oise
FRANCE
Tel: +33 173 43 98 41
Fax: +33 134 64 44 50
e-mail: info@verder.fr

Germany

Verder Deutschland GmbH
Retsch-Allee 1-5
42781 Haan
GERMANY
Tel: 02104/2333-200
Fax: 02104/2333-299
e-mail: info@verder.de

Hungary

Verder Hungary Kft
Budafoke ut 187 - 189
HU-1117 Budapest
HUNGARY
Tel: 0036 1 3651140
Fax: 0036 1 3725232
e-mail: info@verder.hu

India

Verder India Pumps Pvt
Ltd.
Plot No-3B, D-1 Block,
MIDC Chinchwad,
Pune - 411019
INDIA
e-mail:
Sales@verder.co.in
www.verder.co.in

Italy

Verder Italia
Via Maestri Del lavoro, 5
02100 Vazia, Rieti
ITALY
Tel: +39 07 46 229064
e-mail: info@verder.it

The Netherlands

Verder BV
Leningradweg 5
NL 9723 TP Groningen
THE NETHERLANDS
Tel: +31 50 549 59 00
Fax: +31 50 549 59 01
e-mail: info@verder.nl

Poland

Verder Polska
ul.Porcelanowa 23
PL-40 036 Katowice
POLAND
Tel: +48 32 78 15 032
Fax: +48 32 78 15 034
e-mail: verder@verder.pl

Romania

Verder România
Drumul Balta Doamnei
no 57-61
Sector 3
CP 72-117
032624 Bucuresti
ROMANIA
Tel: +40 21 335 45 92
Fax: +40 21 337 33 92
e-mail: office@verder.ro

Slovak Republik

Verder Slovakia s.r.o.
Silacska 1
SK-831 02 Bratislava
SLOVAK REPUBLIK
Tel: +421 2 4463 07 88
Fax: +421 2 4445 65 78
e-mail: info@verder.sk

South Africa

Verder SA
197 Flaming Rock Avenue
Northlands Business Park
Newmarket Street
ZA Northriding
SOUTH AFRICA
Tel: +27 11 704 7500
Fax: +27 11 704 7515
e-mail: info@verder.co.za

Switzerland

Verder Deutschland GmbH
Sales Switzerland
Retsch-Allee 1-5
D-42781 Haan
GERMANY
Tel: +41 (0)61 331 33 13
Fax: +41 (0)61 331 63 22
e-mail: info@verder.ch

United Kingdom

Verder UK Ltd.
Unit 3 California Drive
Castleford, WF10 5QH
UNITED KINGDOM
Tel: +44 (0) 1924 221 001
Fax: +44 (0) 1132 465 649
e-mail: info@verder.co.uk

United States of America

Verder Inc.
312 Corporate Parkway
Suite 101
Macon, GA 31210
USA
Tel: +1 877 783 7337
Fax: +1 478 476 9867
e-mail: sales@verder-us.com