

VERDERAIR VA 80 (HE) Air-Operated Diaphragm Pump

859.0237

Rev. T
EN

Heavy-duty 3-inch pump with large flow paths for fluid transfer applications, including high-viscosity materials. For professional use only.

See page 4 for model information, including approvals.

125 psi (0.86 MPa, 8.6 bar) Maximum Working Pressure, Aluminum or Stainless Steel Pumps with Aluminum Air Section

100 psi (0.7 MPa, 6.9 bar) Maximum Working Pressure, Polypropylene or Stainless Steel Pumps with Polypropylene Air Section



Important Safety Instructions

Read all warnings and instructions in this manual. Save these instructions.

Aluminum

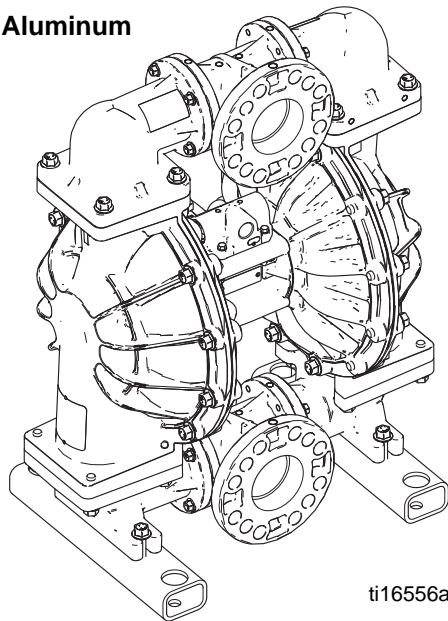

ti16556a

Polypropylene

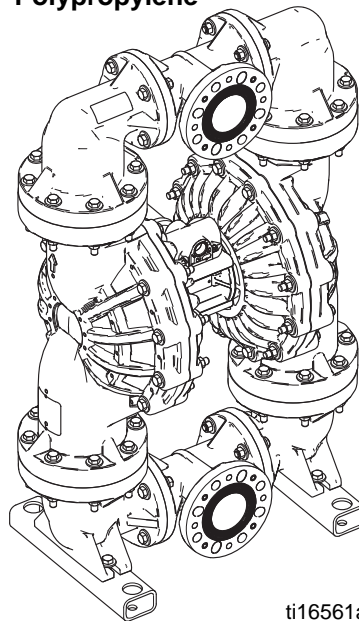

ti16561a

Stainless Steel

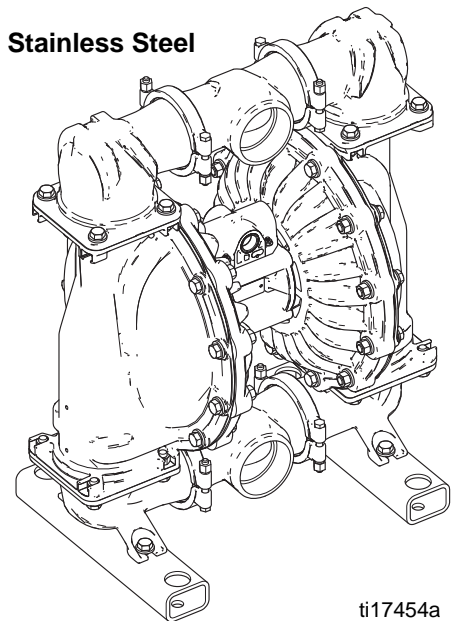

ti17454a

Contents

Related Manuals	2	VA80(HE)S, Stainless Steel	24
To Order a New Pump	3	Parts/Kits Quick Reference	25
To Order Parts for Your Existing Pump	3	Fluid Section	27
Configuration Number Matrix	4	Air Section	29
Warnings	6	Air Valve	32
Troubleshooting	8	Seats and Check Balls	34
Repair	10	Diaphragms	35
Pressure Relief Procedure	10	Accessories	37
Repair or Replace Air Valve	10	Seat, Check Ball, and Diaphragm Kits	38
Check Valve Repair	12	Technical Data	39
Diaphragms and Air Section	14	Customer Services/Guarantee	43
Torque Instructions	20		
Parts	22		
VA80(HE)A, Aluminum	22		
VA80(HE)P, Polypropylene	23		

Related Manuals

Manual	Description
859.0236	VERDERAIR VA 80 Air-Operated Diaphragm Pump, Operation

To Order a New Pump

NOTE: Do not configure and order a pump using only this manual. Work with your distributor or follow the steps below.

1. Go to www.verderair.com. Select Verderair Series VA.
2. Click on Pump Configurator.
3. Use the configurator to specify a pump. As you work through, the configurator offers only those options that work with the pump you are building.

To Order Parts for Your Existing Pump

1. Check the identification plate (ID) for the 17-digit Configuration Number of your pump.
2. Use the Configuration Number Matrix on the next page to understand which parts are described by each digit.
3. Refer to pages 22-24 for the main Parts illustrations, and page 25 for the Parts/Kits Quick Reference. Follow the page references on these pages for further ordering information, as needed.

Configuration Number Matrix

Check the identification plate (ID) for the 17-digit Configuration Number of your pump. Use the following matrix to define the components of your pump.

Sample Configuration Number: VA80(HE)AA-SSTFNOTN00

Pump Model	Fluid Section	Air Section	Seats	Balls	Diaphragms	Connections	Options
VA80 (HE)	A	A	SS	TF	NO	TN	00

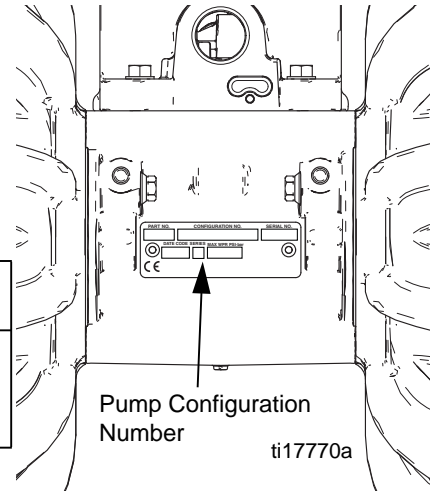

NOTE: Some combinations are not possible. Please check with your local supplier or the pump configurator on www.verderair.com.

Pump Model	Fluid Section Material		Air Section Material		Check Valve Seats		Check Valve Balls	
	Code	Material	Code	Material	Code	Material	Code	Material
VA80(HE)	A	Aluminum★	A	Aluminum	AC	Acetal	AC	Acetal
	P	Polypropylene†	P	Polypropylene	AL	Aluminum	BN	Buna-N
	S	Stainless Steel★			BN	Buna-N	FK	FKM - Fluoroelastomer
					FK	FKM - Fluoroelastomer	GE	Geolast
					GE	Geolast	HY	TPE
					HY	TPE	NR	Polychloroprene Standard
					PP	Polypropylene	NW	Polychloroprene Weighted
					SP	Santoprene	SP	Santoprene
					SS	Stainless Steel	TF	PTFE

★ **VA80(HE)AA** and **VA80(HE)SA** are certified:

II 2 GD
Ex h IIC 66°C...135°C Gb
Ex h IIIC T135°C Db



† **VA80(HE)PA**, **VA80(HE)PP**, and **VA80(HE)SP** are not ATEX certified.

ATEX T-code rating is dependent on the temperature of the fluid being pumped. Fluid temperature is limited by the materials of the pump interior wetted parts. See **Technical Data** for the maximum fluid operating temperature for your specific pump model.

Diaphragm		Connections		Options	
BN	Buna-N	FC	Center Flange, DIN/ANSI	00	Standard
GE	Geolast	TB	Threaded BSP		
NO	Polychloroprene Overmolded	TN	Threaded NPT		
TO	PTFE/EPDM Over- molded				
SP	Santoprene				
TF	PTFE/Santoprene Two-Piece				

Warnings

The following warnings are for the setup, use, grounding, maintenance, and repair of this equipment. The exclamation point symbol alerts you to a general warning and the hazard symbol refers to procedure-specific risk. When these symbols appear in the body of this manual, refer back to these Warnings. Additional, product-specific warnings may be found throughout the body of this manual where applicable.

 <h2 style="margin: 0;">WARNING</h2>	
	<p>FIRE AND EXPLOSION HAZARD</p> <p>Flammable fumes, such as solvent and paint fumes, in work area can ignite or explode. To help prevent fire and explosion:</p> <ul style="list-style-type: none"> • Use equipment only in well ventilated area. • Eliminate all ignition sources; such as pilot lights, cigarettes, portable electric lamps, and plastic drop cloths (potential static arc). • Keep work area free of debris, including solvent, rags and gasoline. • Do not plug or unplug power cords, or turn power or light switches on or off when flammable fumes are present. • Ground all equipment in the work area. See Grounding instructions. • Use only grounded hoses. • Hold gun firmly to side of grounded pail when triggering into pail. Do not use pail liners unless they are antistatic or conductive. • Stop operation immediately if static sparking occurs or you feel a shock. Do not use equipment until you identify and correct the problem. • Keep a working fire extinguisher in the work area. • Route exhaust away from all ignition sources. If diaphragm ruptures, fluid may be exhausted with air. <p>Static charge may build up on plastic parts during cleaning and could discharge and ignite flammable vapors. To help prevent fire and explosion:</p> <ul style="list-style-type: none"> • Clean plastic parts only in a well ventilated area. • Do not clean with a dry cloth. • Do not operate electrostatic guns in equipment work area.
	<p>PRESSURIZED EQUIPMENT HAZARD</p> <p>Fluid from the equipment, leaks, or ruptured components can splash in the eyes or on skin and cause serious injury.</p> <ul style="list-style-type: none"> • Follow the Pressure Relief Procedure when you stop spraying/dispensing and before cleaning, checking, or servicing equipment. • Tighten all fluid connections before operating the equipment. • Check hoses, tubes, and couplings daily. Replace worn or damaged parts immediately.

WARNING



EQUIPMENT MISUSE HAZARD

Misuse can cause death or serious injury.

- Do not operate the unit when fatigued or under the influence of drugs or alcohol.
- Do not exceed the maximum working pressure or temperature rating of the lowest rated system component. See **Technical Data** in all equipment manuals.
- Use fluids and solvents that are compatible with equipment wetted parts. See **Technical Data** in all equipment manuals. Read fluid and solvent manufacturer's warnings. For complete information about your material, request MSDS from distributor or retailer.
- Do not leave the work area while equipment is energized or under pressure.
- Turn off all equipment and follow the **Pressure Relief Procedure** when equipment is not in use.
- Check equipment daily. Repair or replace worn or damaged parts immediately with genuine manufacturer's replacement parts only.
- Do not alter or modify equipment. Alterations or modifications may void agency approvals and create safety hazards.
- Make sure all equipment is rated and approved for the environment in which you are using it.
- Use equipment only for its intended purpose. Call your distributor for information.
- Route hoses and cables away from traffic areas, sharp edges, moving parts, and hot surfaces.
- Do not kink or over bend hoses or use hoses to pull equipment.
- Keep children and animals away from work area.
- Comply with all applicable safety regulations.



THERMAL EXPANSION HAZARD

Fluids subjected to heat in confined spaces, including hoses, can create a rapid rise in pressure due to the thermal expansion. Over-pressurization can result in equipment rupture and serious injury.

- Open a valve to relieve the fluid expansion during heating.
- Replace hoses proactively at regular intervals based on your operating conditions.



PRESSURIZED ALUMINUM PARTS HAZARD

Use of fluids that are incompatible with aluminum in pressurized equipment can cause serious chemical reaction and equipment rupture. Failure to follow this warning can result in death, serious injury, or property damage.

- Do not use 1,1,1-trichloroethane, methylene chloride, other halogenated hydrocarbon solvents or fluids containing such solvents.
- Many other fluids may contain chemicals that can react with aluminum. Contact your material supplier for compatibility.



PLASTIC PARTS CLEANING SOLVENT HAZARD

Many solvents can degrade plastic parts and cause them to fail, which could cause serious injury or property damage.

- Use only compatible water-based solvents to clean plastic structural or pressure-containing parts.
- See **Technical Data** in this and all other equipment instruction manuals. Read fluid and solvent manufacturer's MSDSs and recommendations.

Troubleshooting



Problem	Cause	Solution
Pump cycles but will not prime.	Pump is running too fast, causing cavitation before prime.	Reduce air inlet pressure.
	Check valve ball severely worn or wedged in seat or manifold.	Replace ball and seat. See page 12.
	Seat severely worn.	Replace ball and seat. See page 12.
	Outlet or inlet clogged.	Unclog.
	Inlet or outlet valve closed.	Open.
	Inlet fittings or manifolds loose.	Tighten.
	Manifold o-rings damaged.	Replace o-rings. See page 12.
Pump cycles at stall or fails to hold pressure at stall.	Worn check valve balls, seats, or o-rings.	Replace. See page 12.
Pump will not cycle, or cycles once and stops.	Air valve is stuck or dirty.	Disassemble and clean air valve. See page 10. Use filtered air.
	Check valve ball severely worn and wedged in seat or manifold.	Replace ball and seat. See page 12.
	Pilot valve worn, damaged, or plugged.	Replace pilot valve. See page 14.
	Air valve gasket damaged.	Replace gasket. See page 10.
	Dispensing valve clogged.	Relieve pressure and clear valve.
Pump operates erratically.	Clogged suction line.	Inspect; clear.
	Sticky or leaking check valve balls.	Clean or replace. See page 12.
	Diaphragm (or backup) ruptured.	Replace. See page 14.
	Restricted exhaust.	Remove restriction.
	Pilot valves damaged or worn.	Replace pilot valves. See page 14.
	Air valve damaged.	Replace air valve. See page 10.
	Air valve gasket damaged.	Replace air valve gasket. See page 10.
	Air supply erratic.	Repair air supply.
	Exhaust muffler icing.	Use drier air supply.
Air bubbles in fluid.	Suction line is loose.	Tighten.
	Diaphragm (or backup) ruptured.	Replace. See page 14.
	Loose manifolds, damaged seats or o-rings.	Tighten manifold bolts or replace seats or o-rings. See page 12.
	Diaphragm shaft bolt o-ring damaged.	Replace o-ring.
	Pump cavitation.	Reduce pump speed or suction lift.
	Loose diaphragm shaft bolt.	Tighten.

Problem	Cause	Solution
Exhaust air contains fluid being pumped.	Diaphragm (or backup) ruptured.	Replace. See page 14.
	Loose diaphragm shaft bolt.	Tighten or replace. See page 14.
	Diaphragm shaft bolt o-ring damaged.	Replace o-ring. See page 14.
Moisture in exhaust air.	High inlet air humidity.	Use drier air supply.
Pump exhausts excessive air at stall.	Worn air valve cup or plate.	Replace cup and plate. See page 10.
	Damaged air valve gasket.	Replace gasket. See page 10.
	Damaged pilot valve.	Replace pilot valves. See page 14.
	Worn shaft seals or bearings.	Replace shaft seals or bearings. See page 14.
Pump leaks air externally.	Air valve or fluid cover screws loose.	Tighten.
	Diaphragm damaged.	Replace diaphragm. See page 14.
	Air valve gasket damaged.	Replace gasket. See page 10.
	Air cover gasket damaged.	Replace gasket. See page 14.
Pump leaks fluid externally from joints.	Loose manifold screws or fluid cover screws.	Tighten manifold screws or fluid cover screws. See page 20.
	Manifold o-rings worn out.	Replace o-rings. See page 12.

Repair

Pressure Relief Procedure



Follow the Pressure Relief Procedure whenever you see this symbol.



This equipment stays pressurized until pressure is relieved manually. To help prevent serious injury from pressurized fluid, such as splashing in the eyes or on skin, follow the Pressure Relief Procedure whenever you stop pumping and before you clean, check, or service the equipment.

1. Shut off the air supply to the pump.
2. Open the dispensing valve, if used.
3. Open the fluid drain valve to relieve fluid pressure. Have a container ready to catch the drainage.

Repair or Replace Air Valve



Replace Complete Air Valve

1. Stop the pump. Relieve the pressure. See **Pressure Relief Procedure** in previous section.
2. Disconnect the air line to the motor.
3. Remove screws (104, metal pumps) or nuts (116, plastic pumps). Remove the air valve and gasket (113).
4. To repair the air valve, go to **Disassemble the Air Valve**, step 1, in next section. To install a replacement air valve, continue with step 5.
5. Align the new air valve gasket (113*) on the center housing, then attach the air valve. See **Torque Instructions**, page 20.
6. Reconnect the air line to the motor.

Replace Seals or Rebuild Air Valve

NOTE: Repair kits are available. See page 33 to order the correct kit(s) for your pump. Air Valve Seal Kit parts are marked with a †. Air Valve Repair Kit parts are marked with a ◆. Air Valve End Cap Kit parts are marked with a ✕.

Disassemble the Air Valve

NOTE: The detent assembly (203), cam (204) and spring (211) are not used in air valve 859.0271, for models with PTFE overmolded diaphragms (TO).

1. Perform steps 1-3 under **Replace Complete Air Valve**, page 10.
2. See FIG. 2. Use a Torx screwdriver (T8 for aluminum centers, T10 for plastic centers) to remove two screws (209). Remove the valve plate (205), cup assembly (212-214), spring (211), and detent assembly (203).
3. Pull the cup (213) off of the base (212). Remove the o-ring (214) from the cup.
4. See FIG. 2. Remove the retaining ring (210) from each end of the air valve. Use the piston (202) to push the end cap (207) out of one end. Remove the u-cup seal (208). Pull the piston out the end and remove the other u-cup seal (208). Remove the other end cap (207) and the end cap o-rings (206).
5. Remove the detent cam (204) from the air valve housing (201).

Reassemble the Air Valve

NOTE: Apply lithium-based grease whenever instructed to grease. Order Verder PN 819.0184.

NOTE: The detent assembly (203), cam (204) and spring (211) are not used in air valve 859.0271, for models with PTFE overmolded diaphragms (TO).

1. Use all parts in the repair kits. Clean other parts and inspect for damage. Replace as needed.
2. Grease the detent cam (204◆) and install into housing (201).
3. Grease the u-cups (208◆†) and install on the piston with lips facing toward the center of the piston.

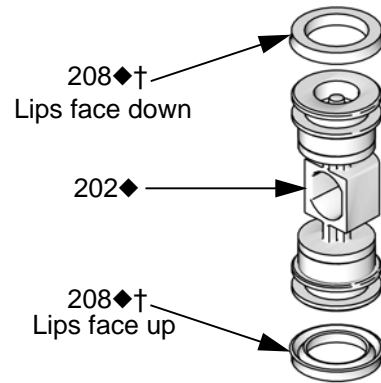

ti12754a

Fig. 1. Air valve u-cup installation

4. Grease both ends of the piston (202◆) and the housing bore. Install the piston in the housing (201), with the flat side toward the cup (213◆). Be careful not to tear u-cups (208◆†) when sliding piston into housing.
5. Grease new o-rings (206◆†⊗) and install on the end caps (207⊗). Install the end caps into the housing.
6. Install a retaining ring (210⊗) on each end to hold end caps in place.

- ⚠ Apply lithium-based grease.
- ⚠ U-cup lips must face piston.
- ⚠ Apply lithium-based grease to contact surface.
- ⚠ These parts are not used in air valve 859.0271.

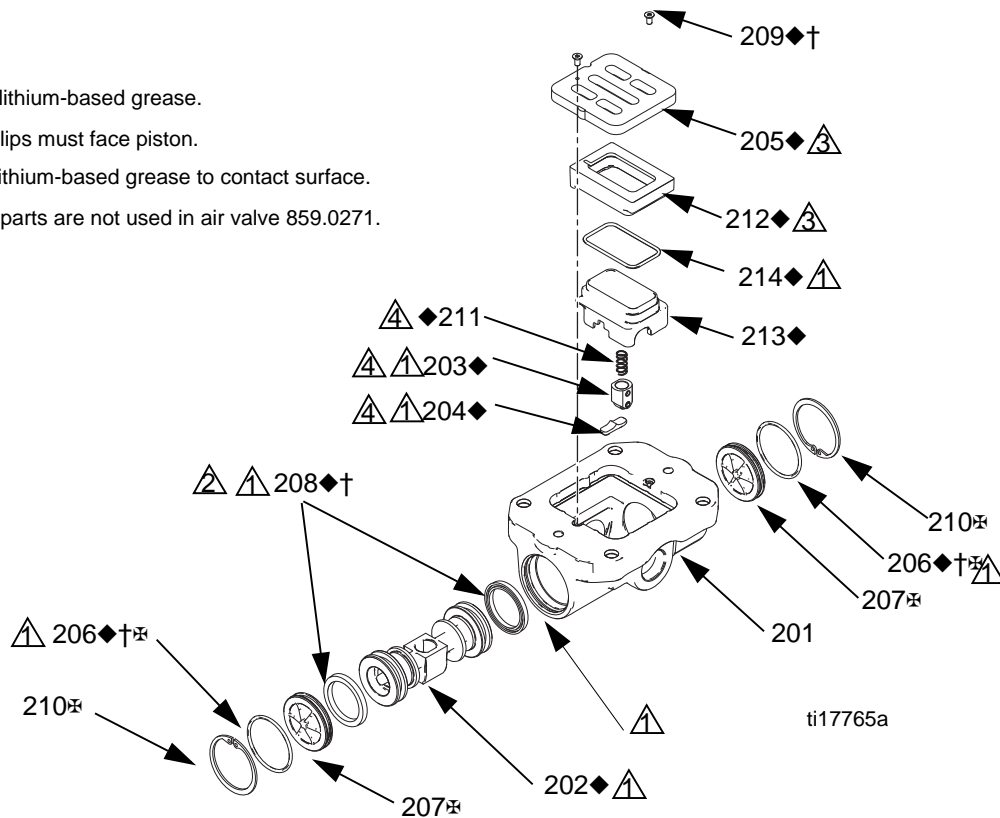

ti17765a

Fig. 2. Air valve assembly

- Grease and install the detent assembly (203♦) into the piston. Install the o-ring (214♦) on the cup (213♦). Apply a light film of grease to the outside surface of the o-ring and the inside mating surface of the base (212♦).

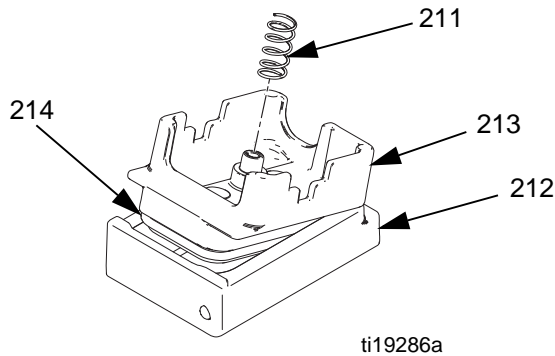

FIG. 3. Cup assembly

Orient the end of the base that has a magnet toward the end of the cup that has the larger cutout. Engage the opposite end of the parts. Leave the end with the magnet free. Tilt the base toward the cup and fully engage the parts, using care so that the o-ring remains in place. Install the spring (211♦) onto the protrusion on the cup. Align the magnet in the base with the air inlet and install the cup assembly.

- Grease the cup side and install the valve plate (205♦). Align the small hole in the plate with the air inlet. Tighten the screws (209♦†) to hold it in place.

Check Valve Repair



NOTE: Kits are available for new check valve balls and seats in a range of materials. See page 34 to order kits in the material(s) desired. O-ring and fastener kits also are available.

NOTE: To ensure proper seating of the check balls, always replace the seats when replacing the balls. Also, on models with seat o-rings, replace the o-rings every time the manifold is removed.

Disassembly

- Follow the **Pressure Relief Procedure** on page 10. Disconnect all hoses.

NOTE: The pump is heavy. Always use two people or a lift to move it.

- Remove the pump from its mounting.

NOTE: For plastic pumps (VA80(HE)PA, VA80(HE)PP), use hand tools until thread-locking adhesive patch releases.

- Use a 3/4 in. (19 mm) socket wrench to remove the outlet elbow fasteners (8), then remove the manifold assembly. See FIG. 4.
- Remove the o-rings (13, *not used on some models*), seats (11), and balls (12).
- Turn the pump over and remove the inlet manifold. The mounting brackets will remain attached.
- Remove the o-rings (13, *not used on some models*), seats (11), and balls (12).

Reassembly

- Clean all parts and inspect for wear or damage. Replace parts as needed.
- Reassemble in the reverse order, following all notes in FIG. 4. Put the inlet manifold on first. Be sure the ball checks (11-13) and manifolds are assembled **exactly** as shown. The arrows (A) on the fluid covers **must** point toward the outlet manifold.

⚠ Torque to 54-61 Nm (40-45 ft-lb) for Polypropylene models.
Torque to 75-81 Nm (55-60 ft-lb) for Aluminum models.
Torque to 54-61 Nm (40-45 ft-lb) for Stainless Steel models.
See **Torque Instructions**, page 20.

⚠ Arrow (A) must point toward outlet manifold.

⚠ Not used on some models.

Polypropylene pump shown

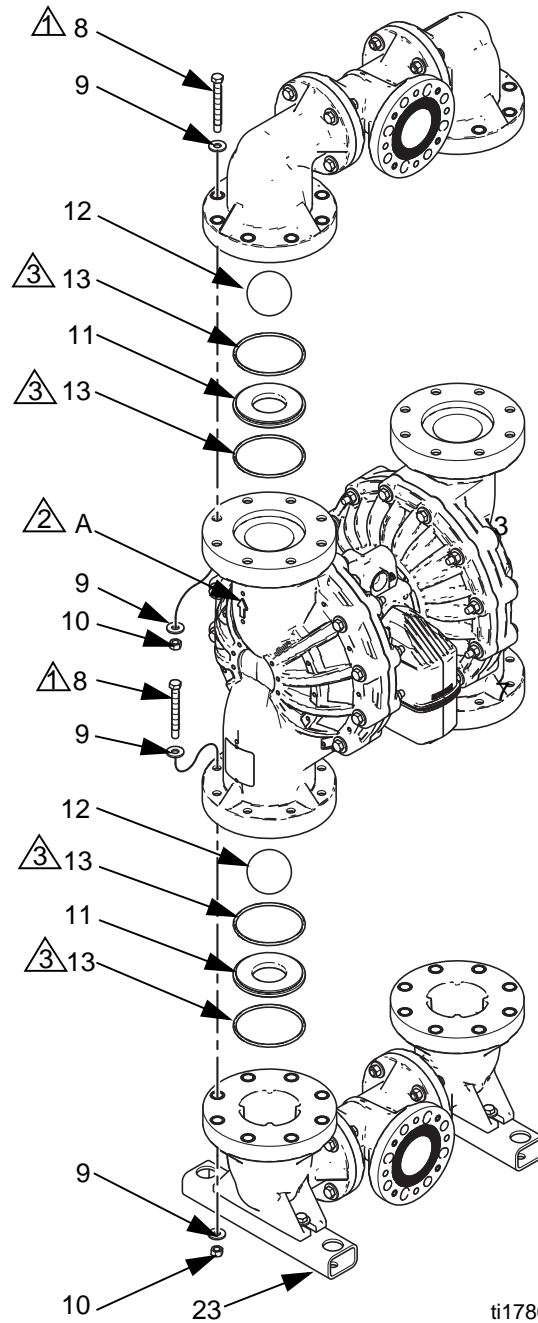

ti17808a

FIG. 4. Ball check valve assembly

Diaphragms and Air Section

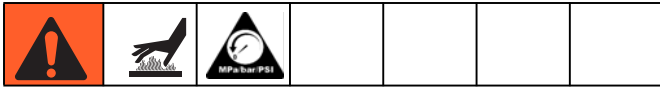

Disassembly

NOTE: Diaphragm kits are available in a range of materials and styles. See page 35 to order the correct diaphragms for your pump. An Air Section Rebuild Kit also is available. See page 31. Parts included in the Air Section Rebuild Kit are marked with an *. For best results, use all kit parts.

1. Follow the **Pressure Relief Procedure** on page 10.
2. Remove the manifolds and disassemble the ball check valves as explained on page 12.

NOTE: You may wish to remove the inner fluid cover bolts (37) as you remove each manifold, for convenience.

3. Overmolded Diaphragms (TO and NO)

- a. Orient the pump so one of the fluid covers faces up. Use a 3/4 in. (19 mm) socket wrench to remove the fluid cover bolts (36, 37), then pull the fluid cover (2) up off the pump.
- b. The exposed diaphragm (20) will screw off by hand. The shaft will either release and come off with this diaphragm, or remain attached to the other diaphragm. If the diaphragm shaft bolt (16) remains attached to the shaft (108), remove it. Remove the air side diaphragm plate (14) and washer (18).
- c. Turn the pump over and remove the other fluid cover. Remove the diaphragm (and the shaft, if necessary).
- d. If the shaft is still attached to either diaphragm, grasp the diaphragm firmly and use a wrench on the flats of the shaft to remove. Also remove the air side diaphragm plate (14) and washer (18). Continue with Step 5.

4. All Other Diaphragms

- a. Orient the pump so one of the fluid covers faces up. Use a 3/4 in. (19 mm) socket wrench to remove the fluid cover screws (36, 37), then pull the fluid cover (2) up off the pump. Turn the pump over and remove the other fluid cover.

- b. **Plastic Pumps:** Hold the hex of one fluid side diaphragm plate (15) with a 1-5/8 socket or box end wrench. Use another wrench (same size) on the hex of the other plate to remove. Then remove all parts of the diaphragm assembly. See FIG. 7.

Metal Pumps: Turn the pump on its side. Hold one diaphragm shaft bolt (16) with a wrench, then use a 15/16 socket to remove the other bolt. Remove all parts of the diaphragm assembly. See FIG. 7, page 17.

- c. Disassemble the other diaphragm assembly.
5. Use an o-ring pick to remove the u-cup packings (101) from the center housing. Bearings (109) can remain in place.
6. If necessary, remove the pilot valves (110).

Air Covers

Remove air covers only if a serious air leak suggests that the gaskets need to be replaced.

1. Remove pilot valves (110).
2. Use a 3/8 allen wrench (aluminum) or a 5/8 socket (polypropylene) to remove two bolts (103), then remove one air cover (105). Repeat for the other air cover.
3. Remove and replace the gasket (107).
4. Inspect the diaphragm shaft (108) for wear or scratches. If it is damaged, inspect the bearings (109) in place. If they are damaged, use a bearing puller to remove them.

NOTE: Do not remove undamaged bearings.

Reassembly of Housing Parts and Air Covers

Follow all notes in FIG. 5. These notes contain important information.

NOTE: Apply lithium-based grease whenever instructed to grease. Order Verder PN 819.0184.

1. Clean all parts and inspect for wear or damage. Replace parts as needed.

NOTICE

Unwanted pressurized air due to worn seals can lead to reduced diaphragm life.

2. Grease and install the diaphragm shaft u-cup packings (101*) so the lips face **out** of the housing.
3. If removed, insert the new bearings (109*) into the center housing. Use a press or a block and rubber mallet to press-fit the bearing so it is flush with the surface of the center housing.

4. Assemble air covers, if removed:
 - a. Put one air cover on the bench. Install the alignment pins (112*) and a new gasket (107*).
 - b. Carefully place the center section on the air cover.
 - c. Install second set of alignment pins (112*) and gasket (107*) in the center section. Lower the second air cover onto the center housing.
 - d. **Aluminum Centers:** Apply medium-strength (blue) thread locker on the bolts (103). Install two bolts and torque to 41-54 Nm (30-40 ft-lb). Turn the pump over on the bench and install and torque the other two bolts.
Poly Centers: Apply medium-strength (blue) thread locker on the bolts (103) and install a washer (119) on each bolt. Turn the assembly on its side. The alignment pins will help hold it together. Slide one bolt (103) through from one air cover to the other. Install a washer (119) and nut (118), hand tight. Repeat for the other three bolts, then torque to 34-47 Nm (25-35 ft-lb).
5. Grease and install the pilot valves (110*). Torque to 2.3-2.8 Nm (20-25 in.-lb). Do not over-torque.

 Apply lithium-based grease.

 Lips must face out of housing.

 Aluminum: Torque to 41-54 Nm (30-40 ft-lb.).
Poly: Torque to 34-47 Nm (25-35 ft-lb.).

 Torque to 2.3-2.8 Nm (20-25 in.-lb).

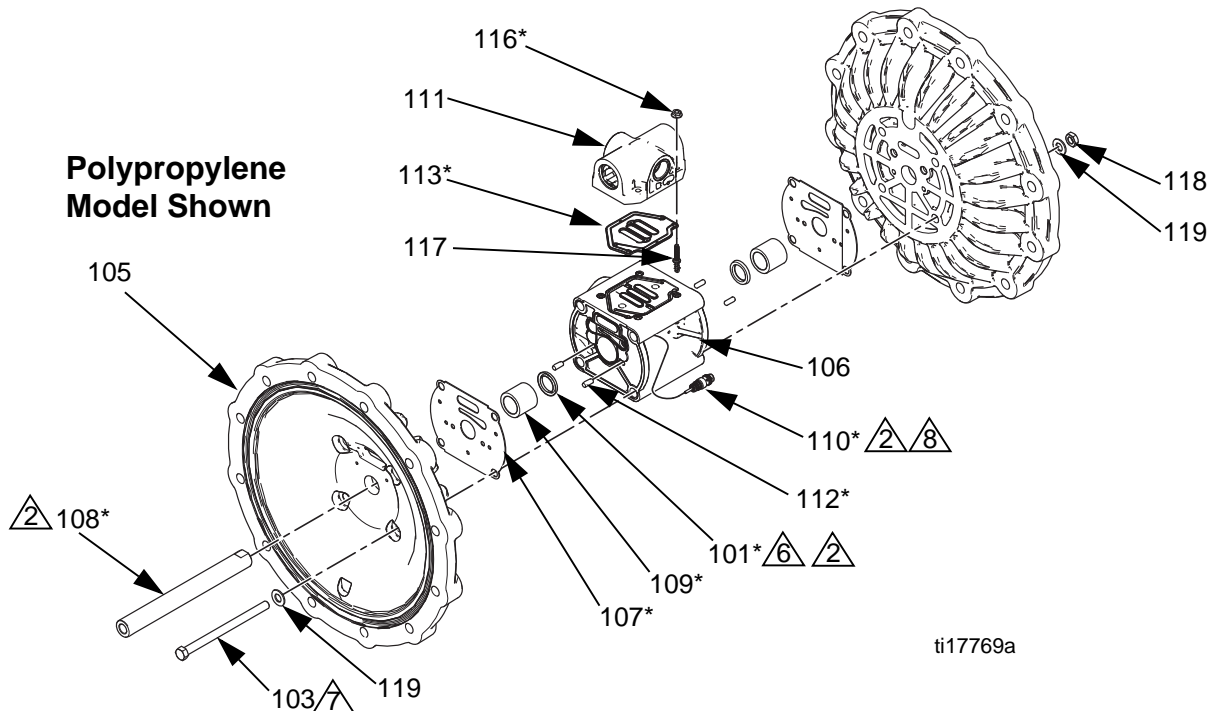

FIG. 5. Assemble Air Section

Reassembly of Standard Diaphragms

NOTE: If your pump has overmolded diaphragms, see page 19.

PTFE Diaphragms

1. Clean all parts and inspect for wear or damage. Replace parts as needed.
 2. Clamp the shaft flats in a vise.
 3. For metal pumps, install the washer (18) and o-ring (17) on the shaft bolt (16).
 4. Assemble the fluid side plate (15), the diaphragm (20), the backup diaphragm (305), the air side diaphragm plate (14), and the washer (18) on the bolt exactly as shown in FIG. 7.
 5. Apply medium-strength (blue) Loctite or equivalent to the bolt (16) threads. Assemble into shaft. Torque the bolt to 149-163 Nm (110 -120 ft-lb) at 100 rpm maximum.
 6. Grease the shaft u-cups (101*) and the length and ends of the diaphragm shaft (108*). Slide the shaft into the housing.
 7. Repeat Steps 3 and 4 for the other diaphragm assembly.
 8. Apply medium-strength (blue) Loctite or equivalent to the bolt (16) threads. Screw the bolt into the shaft hand tight.
 9. To keep the diaphragms properly aligned, place 4 bolts on the side that has been torqued. Screw into the air cover just enough to engage two threads.
- NOTE:** The fluid cover bolts may work well, or use shop bolts. Do not use bolts that are long enough to deform the diaphragm manually.
10. Clamp the torqued side in a vise.
 11. Again align the diaphragm and air cover holes on the second side and place 4 more bolts.

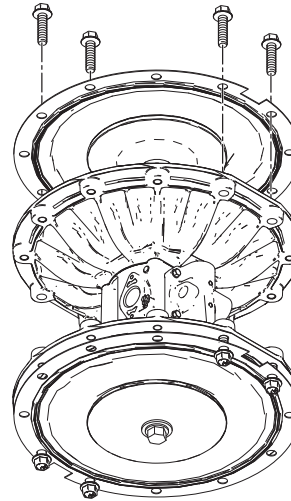

ti18621a

FIG. 6. Place bolts to keep PTFE diaphragms aligned.

12. Torque the shaft bolt on the second side to 149-163 Nm (110 -120 ft-lb) at 100 rpm maximum.
13. Remove the bolts used for alignment.
14. Reattach one fluid cover (2). Arrow (A) must point toward the air valve. See **Torque Instructions**, page 20.
15. Follow directions under **Attach Second Fluid Cover**, page 19.
16. Reassemble the ball check valves and manifolds as explained on page 12.

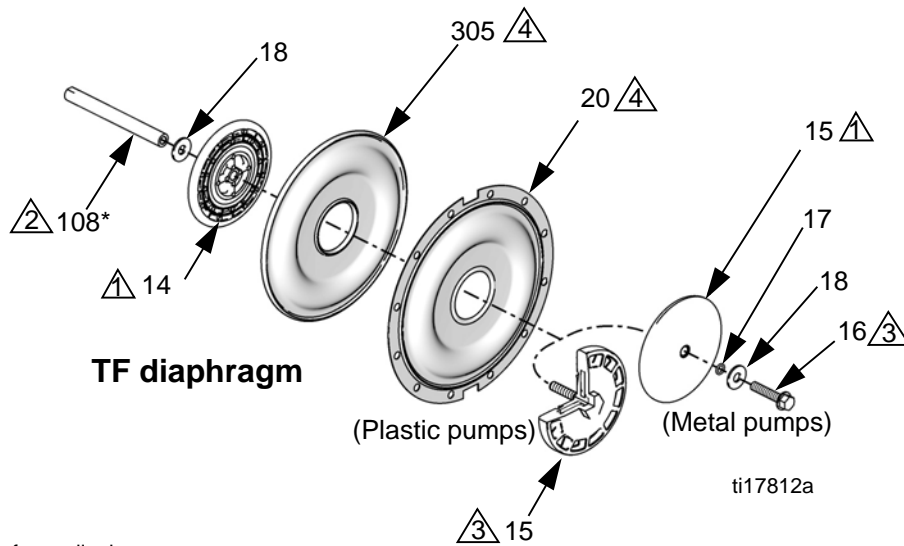
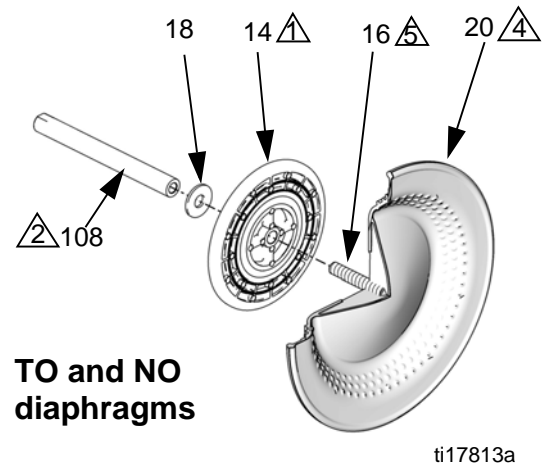
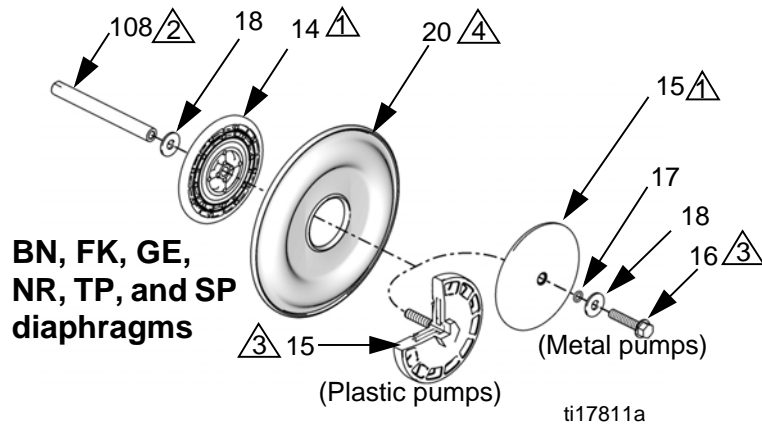

- 1 Rounded side faces diaphragm.
- 2 Apply lithium-based grease.
- 3 Torque to 149-163 Nm (110-120 ft.-lb.) at 100 rpm maximum.
- 4 AIR SIDE markings on diaphragm must face center housing.
- 5 If screw comes loose or is replaced, apply permanent (red) Loctite® or equivalent to diaphragm side threads. Apply primer and medium-strength (blue) Loctite® or equivalent to shaft side threads.

FIG. 7. Assemble diaphragms.

All Other Standard Diaphragms - Metal Pumps:

1. Install the washer (18) and o-ring (17) on the shaft bolt (16).
2. Assemble the fluid side plate (15), the diaphragm (20), the air side diaphragm plate (14), and the washer (18) on the bolt exactly as shown in FIG. 7.
3. Apply medium-strength (blue) Loctite or equivalent to the bolt (16) threads. Screw the bolt into the shaft hand tight.
4. Grease the shaft u-cups (101*) and the length and ends of the diaphragm shaft (108*). Slide the shaft into the housing.
5. Repeat Steps 1-5 for the other diaphragm assembly.
6. Hold one shaft bolt with a wrench and torque the other bolt to 149-163 Nm (110-120 ft-lb) at 100 rpm maximum. Do not over-torque.
7. Reattach one fluid cover (2). Arrow (A) must point toward the air valve. See **Torque Instructions**, page 20.
8. **TF, SN, and GE Diaphragms:** Follow directions under **Attach Second Fluid Cover**, page 19.

NR, BN, and FK Diaphragms: Reattach the second fluid cover (2). Arrow (A) must point toward the air valve. See **Torque Instructions**, page 20.

9. Reassemble the ball check valves and manifolds as explained on page 12.

All Other Standard Diaphragms - Plastic Pumps:

1. Assemble the diaphragm (20), the air side diaphragm plate (14), and the washer (18) on the fluid side plate (15) exactly as shown in FIG. 7.
2. Apply medium-strength (blue) Loctite or equivalent to the threads of the screw on the fluid side plate. Screw the assembly into the shaft hand-tight.
3. Grease the shaft u-cups (101*) and the length and ends of the diaphragm shaft (108*). Slide the shaft into the housing.
4. Repeat for the other diaphragm assembly.
5. Hold one of the plates with a wrench, and torque the other plate to 149-163 Nm (110-120 ft-lb) at 100 rpm maximum. Do not over-torque.
6. Reattach one fluid cover (2). Arrow (A) must point toward the air valve. See **Torque Instructions**, page 20.
7. **TF, SN, and GE Diaphragms:** Follow directions under **Attach Second Fluid Cover**, page 19.
NR, BN, and FK Diaphragms: Reattach the second fluid cover (2). Arrow (A) must point toward the air valve. See **Torque Instructions**, page 20.
8. Reassemble the ball check valves and manifolds as explained on page 12.

Attach Second Fluid Cover

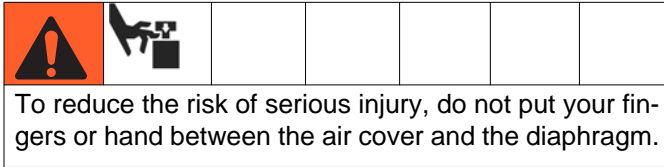

To ensure proper seating and help attain expected diaphragm life, attach the second fluid cover with air pressure on the pump. This procedure is needed for overmolded diaphragms (TO and NO) and for the following standard diaphragms: GE, SP, TF.

1. Place the supplied tool (302) where the air valve gasket (113*) normally goes. Arrows (A) must face toward the fluid cover that is already attached.

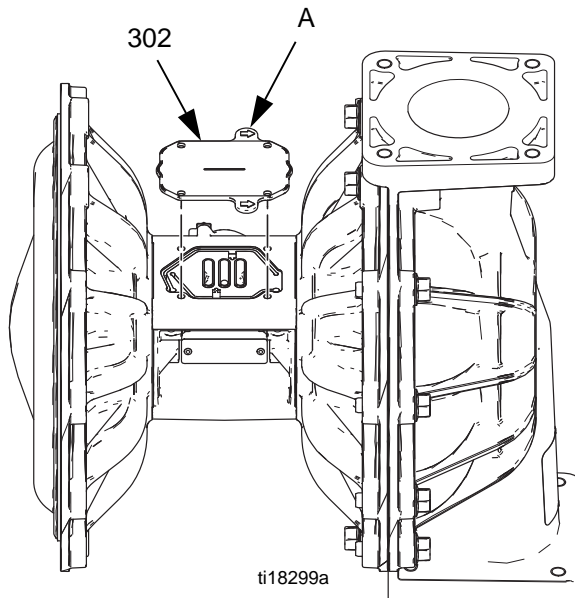

Fig. 8. Diaphragm Installation Tool

2. Reattach the air valve.
3. Supply the pump with low pressure air, just enough to move the diaphragm. For standard diaphragms, use about 10 psi (0.07 MPa, 0.7 bar); for overmolded diaphragms use about 20 psi (0.14 MPa, 1.4 bar). Shop air may be used. The diaphragm will shift so the second fluid cover will seat properly. Keep air pressure on until the second fluid cover is attached.
4. Attach the second fluid cover (2). See **Torque Instructions**, page 20.
5. Remove the air valve and the tool (302), replace the gasket (113), and reattach the air valve. See **Torque Instructions**, page 20.

NOTE: If you are replacing the diaphragms but not the air valve, you still must remove the air valve, and replace the gasket with the tool so the air valve can be used for proper installation of the second fluid cover. Remember to remove the tool and replace the gasket when finished.

Reassembly of Overmolded Diaphragms

NOTE: If your pump has standard diaphragms, see page 16.

1. Clamp the shaft flats in a vise.
2. If diaphragm setscrew comes loose or is replaced, apply permanent (red) Loctite® or equivalent to diaphragm side threads. Screw into diaphragm until tight.
3. Assemble the air side plate (14) and washer (18) onto the diaphragm. The rounded side of the plate must face the diaphragm.
4. Apply medium-strength (blue) Loctite or equivalent to the threads of the diaphragm assembly. Screw the assembly into the shaft as tight as possible by hand.
5. Grease the shaft u-cups (101*) and the length and ends of the diaphragm shaft (108*). Slide the shaft into the housing.
6. Reattach the first fluid cover (2). Arrow (A) must point toward the air valve. See **Torque Instructions**, page 20.
7. Repeat Steps 2 - 4 for the other diaphragm assembly.
8. Follow directions under **Attach Second Fluid Cover**, page 19.
9. Reassemble the ball check valves and manifolds as explained on page 12.

Torque Instructions

See FIG. 9 for fluid cover and air valve fasteners. See FIG. 10 for manifold fasteners.

NOTE: Fluid cover and manifold fasteners on the polypropylene pumps have a thread-locking adhesive patch applied to the threads. If this patch is excessively worn, the fasteners may loosen during operation. Replace screws with new ones or apply medium-strength (blue) Loctite or equivalent to the threads.

If fluid cover or manifold fasteners have been loosened, it is important to torque them using the following procedure to improve sealing.

NOTE: Always completely torque fluid covers, then torque the manifold pieces together, then torque the assembled manifolds to the fluid covers.

Start all fluid cover screws a few turns. Then turn down each screw just until head contacts cover. Then turn each screw by 1/2 turn or less working in a crisscross pattern to specified torque. Repeat for manifolds.

Fluid cover fasteners:

Polypropylene and Stainless Steel: 54-61 Nm (40-45 ft-lb)

Aluminum: 75-81 Nm (55-60 ft-lb)

Manifold fasteners:

Polypropylene: 54-61 Nm (40-45 ft-lb)

Aluminum:

Refs 1-8: 15-28 Nm (11-21 ft-lb)

Refs 9-16: 75-81 Nm (55-60 ft-lb)

Stainless Steel:

Refs 1-4: 12-13 Nm (110-120 in-lb)

Refs 5-12: 54-61 Nm (40-45 ft-lb)

Retorque the air valve fasteners in a crisscross pattern to specified torque.

Air Valve fasteners

Plastic Air Sections: 5-6.2 Nm (45-55 in-lb)

Aluminum Air Sections: 8.5-9.6 Nm (75-85 in-lb)

Also check and tighten the nuts or bolts (X) holding the manifold feet to the mounting brackets.

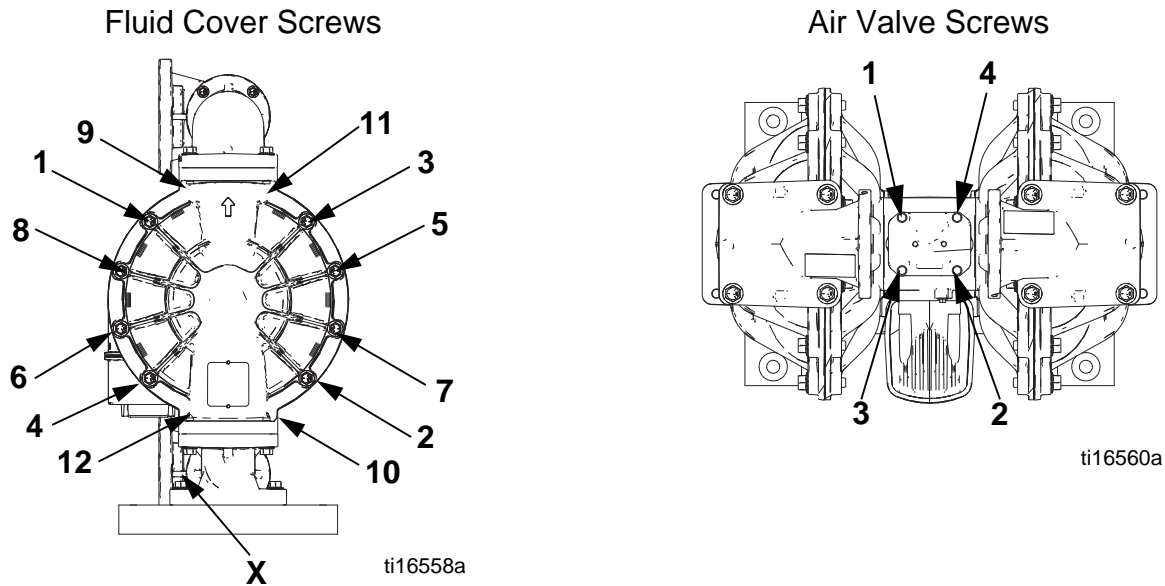

FIG. 9. Torque instructions, Fluid Covers and Air Valve Fasteners (all models, aluminum shown)

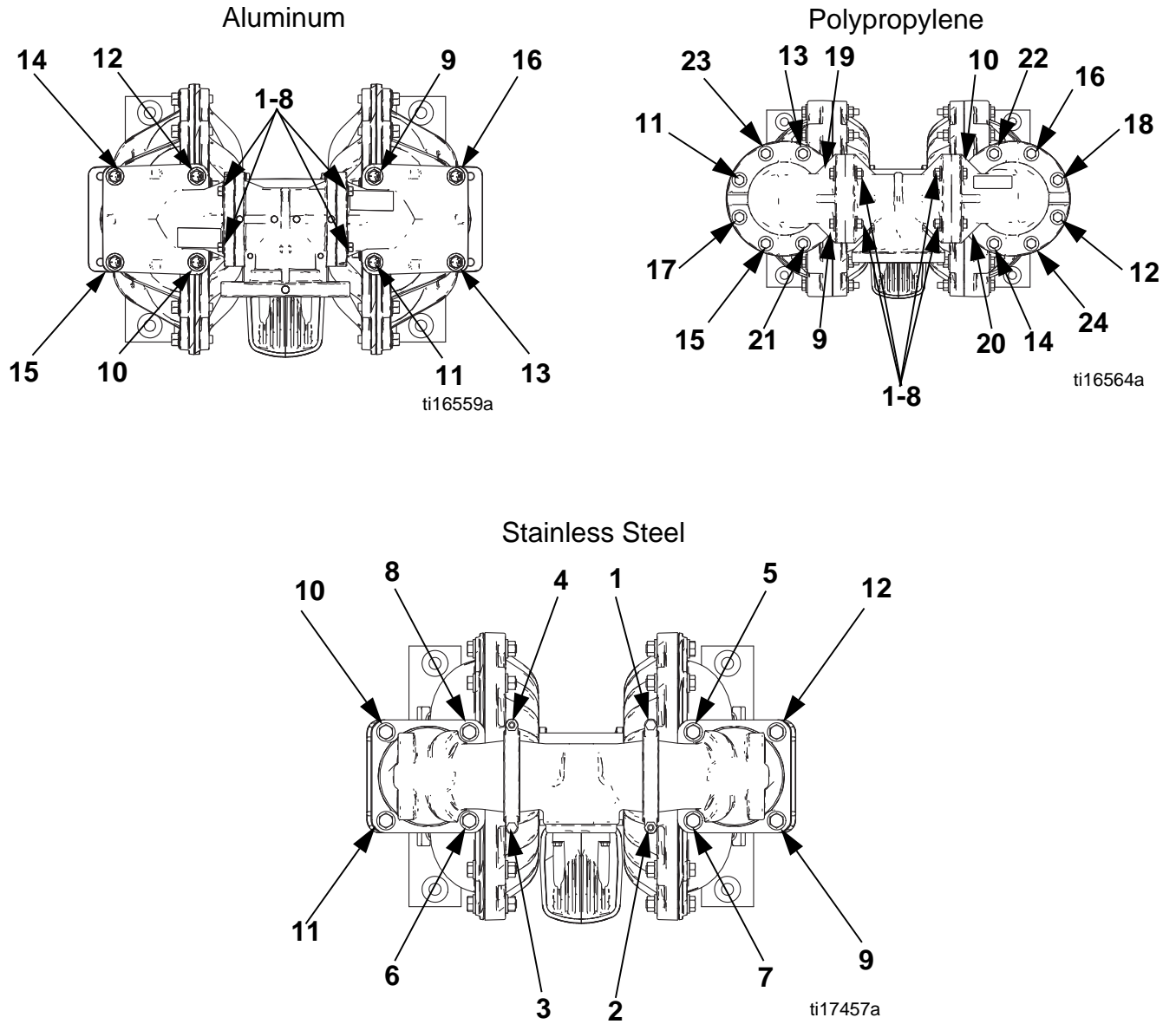
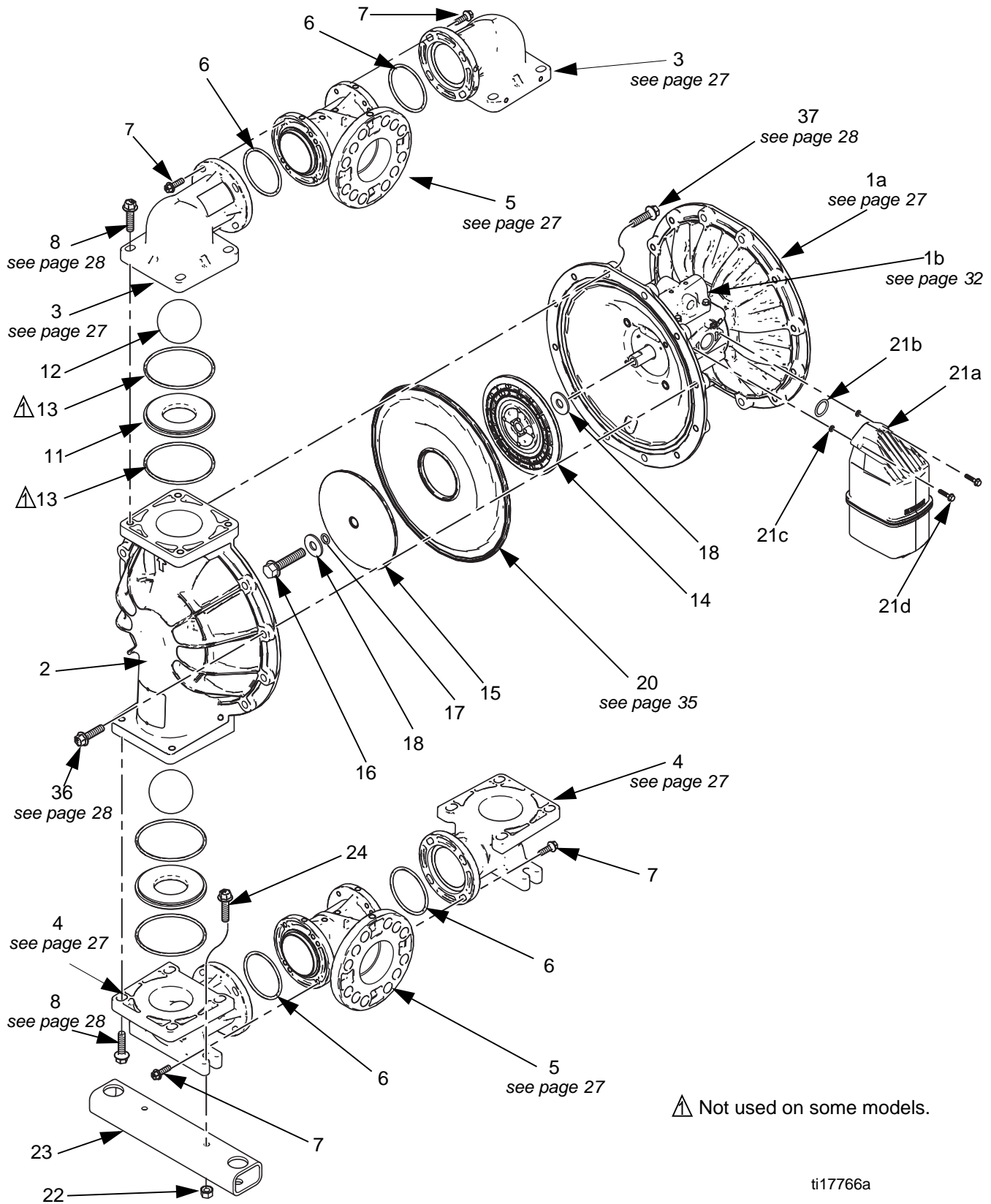

FIG. 10. Torque Instructions - Manifold Fasteners

Parts

VA80(HE)A, Aluminum



VA80(HE)P, Polypropylene

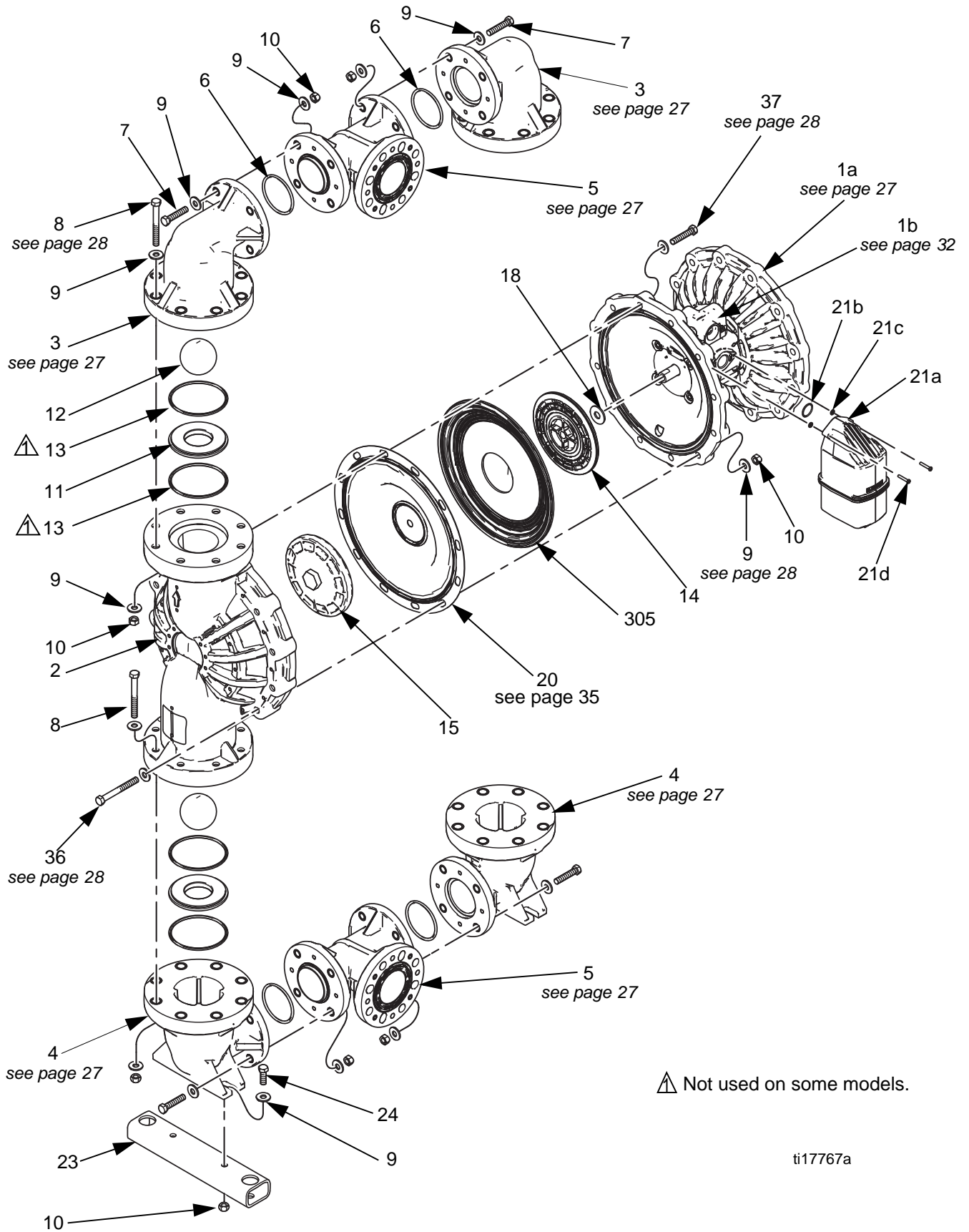

⚠ Not used on some models.

ti17767a

VA80(HE)S, Stainless Steel

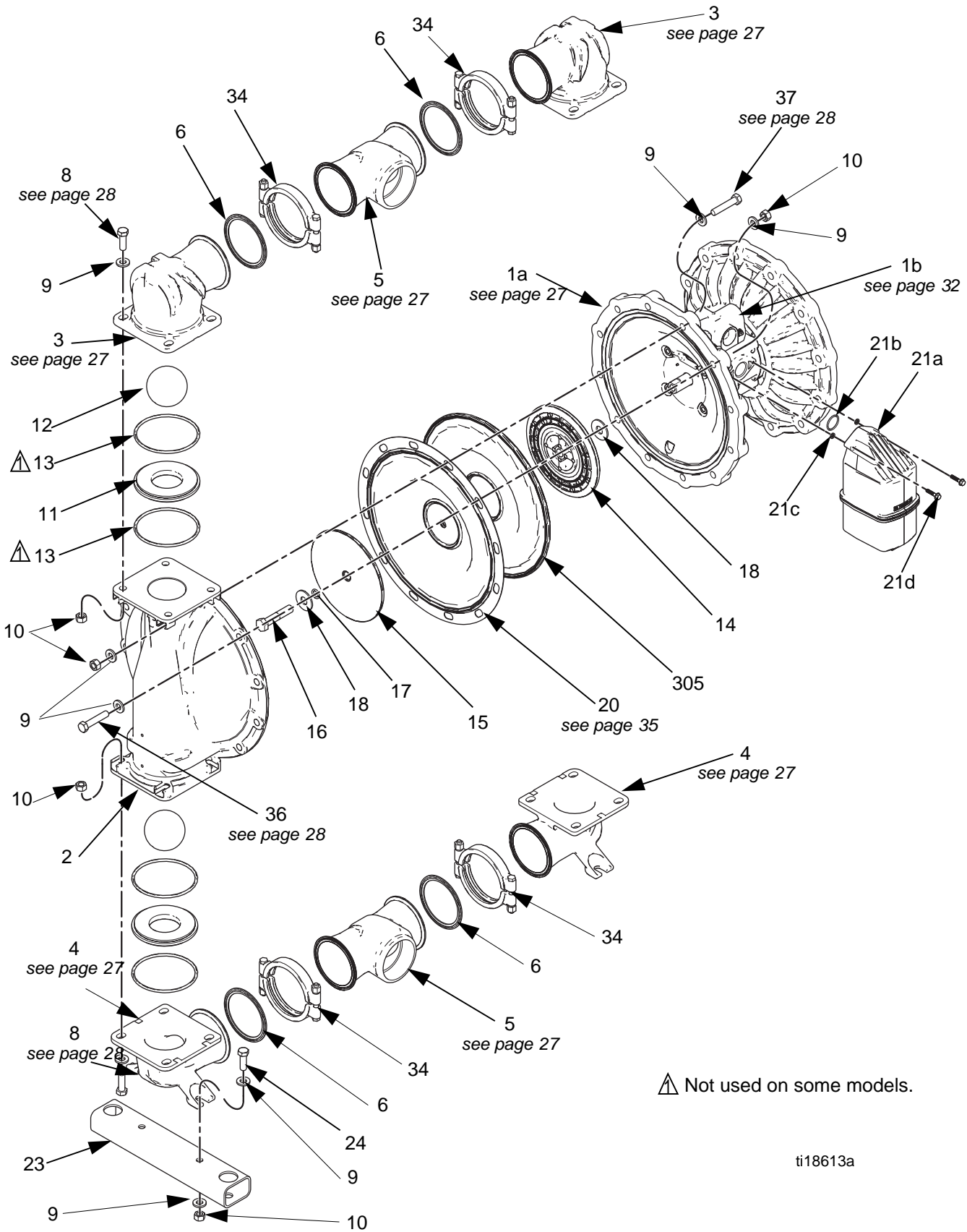

ti18613a

Parts/Kits Quick Reference

Use this table as a quick reference for parts/kits. See pages indicated in table for full description of kit contents.

Ref.	Part/Kit	Description
1a	859.0405 859.0406	AIR SECTION, <i>see page 29</i> Aluminum Polypropylene
1b		AIR VALVE; <i>see page 32</i>
2	859.0171 859.0173 859.0176	FLUID COVER KITS; <i>see page 27</i> Aluminum Polypropylene Stainless Steel
3	859.0185 859.0188 859.0192	MANIFOLD, outlet elbow kits; <i>see page 27.</i> Aluminum Polypropylene Stainless Steel
4	859.0186 859.0189 859.0193	MANIFOLD, inlet elbow kits; <i>see page 27.</i> Aluminum Polypropylene Stainless Steel
5	859.0184 859.0231 859.0190 859.0194 859.0232	MANIFOLD, center kits, <i>see page 27.</i> Aluminum, npt Aluminum, bspt Polypropylene Stainless Steel, npt Stainless Steel, bspt
6	859.0180 859.0179 859.0182	SEAL, manifold joint, <i>see page 28</i> Buna-N, for aluminum and poly PTFE, for aluminum and poly PTFE, for stainless steel
7	859.0187 859.0191	BOLTS, manifold elbows to center, not used on stainless steel, <i>see page 27</i> Aluminum Polypropylene
8	859.0230 859.0183 859.0196	FASTENERS, manifold to fluid cover, <i>see</i> <i>page 28.</i> Aluminum Polypropylene Stainless Steel
9	-----	WASHER, <i>included in fastener kits</i>
10	-----	NUT, <i>included with refs 36 and 37</i>
11	859.0212 859.0213 859.0214 859.0220 859.0215 859.0217 859.0218 859.0219 859.0216	SEATS; 4-pack, <i>see page 34</i> Acetal Aluminum Buna-N FKM Fluoroelastomer Geolast Polypropylene Santoprene Stainless Steel TPE

Ref.	Part/Kit	Description
12	859.0221 859.0222 859.0225 859.0226 859.0229 859.0223 859.0227 859.0228 859.0224	CHECK BALLS; 4-pack, <i>see page 34</i> Acetal Buna-N Polychloroprene, standard Polychloroprene, weighted FKM Fluoroelastomer Geolast PTFE Santoprene TPE
13	859.0209 859.0211	O-RING, seat (not used on some models); 8-pack, <i>see page 34</i> Buna-N PTFE
14	859.0235	PLATE, air side diaphragm, includes o-ring (17) and washer (18)
15	859.0206 859.0207 859.0208	PLATE, fluid side diaphragm, <i>see page 36</i> Aluminum Polypropylene Stainless steel
16	-----	SCREW, hex washer head, 3/8-11x 3 in., carbon steel, included with Ref. 15
17	-----	O-RING, included with Refs. 14 and 15
18	-----	WASHER, included with Refs. 14 and 15
20	859.0197 859.0203 859.0200 859.0198 859.0204 859.0199 859.0205 859.0202 859.0201	DIAPHRAGM Kits; <i>see page 35</i> Buna-N Standard FKM Standard Geolast Standard Polychloroprene Overmolded Polychloroprene Standard PTFE Overmolded PTFE/Santoprene Two-Piece Santoprene Standard TPE Standard

Continued

Parts

Ref.	Part/Kit	Description
21a- 21d	859.0252	MUFFLER, includes o-ring and mounting hardware
23	859.0234 859.0233	BRACKET, mounting, <i>see page 37</i> Aluminum Polypropylene and Stainless Steel
24	-----	BOLT, mounting, 1/2-13 , included in bracket kit
25▲	819.6311	LABEL, warning (not shown)
33▲		TAG, warning, retorque (not shown)
	819.0388	Aluminum
	819.0389	Polypropylene
	819.0390	Stainless Steel
34	859.0195	KIT, manifold clamp, used on stainless steel
36 and 37	859.0172 859.0174 859.0175 859.0177 859.0178	FASTENERS, fluid cover to air cover, <i>see page 28</i> Aluminum Polypropylene, with poly air section Polypropylene, with alum air section Stainless Steel with alum air section Stainless Steel with poly air section

▲Replacement Warning labels, signs, tags, and cards are available at no cost.

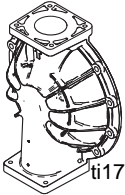
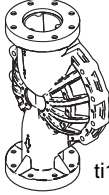
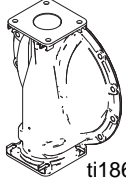

Fluid Section

Sample Configuration Number							
Pump Size	Fluid Section	Air Section	Seats	Balls	Diaphragms	Connections	Options
VA80(HE)	A	A	SS	TF	NO	TN	00

Fluid Cover Kits					
A	859.0171	P	859.0173	S	859.0176
 ti17800a		 ti17803a		 ti18628a	

Kits include:

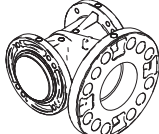
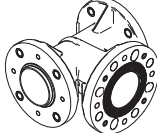
- 1 fluid cover (2)

Manifold Center Kits					
A, npt	859.0184	P	859.0190	S, npt	859.0194
A, bsp	859.0232			S, bsp	859.0231
 ti17802a		 ti17805a		 ti18632a	

Kits include:

- 1 manifold center (5)

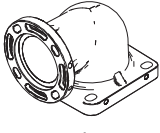
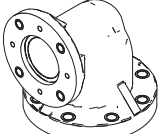
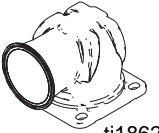
Outlet Manifold Elbow Kits					
A	859.0185	P	859.0188	S	859.0192
 ti17799a		 ti17804a		 ti18629a	

Kits include:

- 1 outlet manifold elbow (3)

Manifold Center Fastener Kits	
Aluminum	859.0187
Polypropylene	859.0191
Stainless steel	859.0195

Aluminum kit includes:

- 8 bolts (7) , hex head with flange base, 3/8-16 x 1.25 in., zinc-plated carbon steel

Polypropylene kit includes:

- 8 bolts (7), hex head, 1/2-13 x 2.5 in., stainless steel
- 16 washers (9)
- 8 nuts (10)

Stainless steel kit includes:

- 2 clamps (7a), 4 in., tri-clamp
- 2 gaskets (7b), 4 in., PTFE

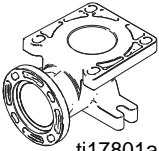
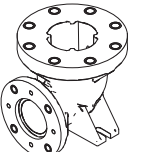
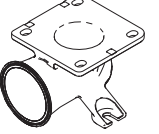
Inlet Manifold Elbow Kits					
A	859.0186	P	859.0189	S	859.0193
 ti17801a		 ti17806a		 ti18630a	

Kits include:

- 1 inlet manifold elbow (4)

Sample Configuration Number							
Pump Size	Fluid Section	Air Section	Seats	Balls	Diaphragms	Connections	Options
VA80(HE)	A	A	SS	TF	NO	TN	00

Manifold to Fluid Cover Fastener Kits	
Aluminum	859.0230
Polypropylene	859.0183
Stainless steel	859.0196

Aluminum kit includes:

- 8 bolts (7), hex head with flange base, 1/2-13 x 1.25 in., zinc-plated carbon steel

Polypropylene kit includes:

- 16 bolts (7), hex head, 1/2-13 x 4 in., stainless steel
- 32 washers, 1/2 in., stainless steel
- 16 nuts, 1/2 in., stainless steel

Stainless steel kit includes:

- 8 bolts, hex head, 1/2-13 x 1.5 in., stainless steel
- 8 washers, 1/2 in., stainless steel
- 8 nuts, 1/2 in., stainless steel

Manifold Center Seal Kits		
	Aluminum and Poly Pumps	Stainless Steel Pumps
TF	859.0179	859.0182
BN	859.0180	not available
FK	859.0181	

Kits for Aluminum or Polypropylene pumps include:

- 4 o-rings (6)
- 1 grease packet

Kit for Stainless Steel pumps includes:

- 4 gaskets (6)

Fluid Cover to Air Cover Fastener Kits	
A	859.0172
P , with poly air section	859.0174
P , with aluminum air section	859.0175
S , with poly air section	859.0178
S , with aluminum air section	859.0177

Aluminum kit Includes:

- 12 bolts (36 and 37), hex head with flange, 1/2-13 x 2 in., zinc-coated carbon steel

Polypropylene with Polypropylene Air Section Kit includes:

- 8 bolts (36), hex head, 1/2-13 x 4 in., stainless steel
- 4 bolts (37), hex head, 1/2-13 x 2.5 in., stainless steel
- 20 washers (9), stainless steel
- 8 nuts (10), hex, stainless steel

Polypropylene with Aluminum Air Section Kit includes:

- 8 bolts (36), hex head, 1/2-13 x 3.25 in., stainless steel
- 4 bolts (37), hex head, 1/2-13 x 2.25 in., stainless steel
- 12 washers (9), stainless steel

Stainless Steel with Aluminum Air Section Kit includes:





- 8 bolts (36), hex head, 1/2-13 x 1.5 in., stainless steel
- 4 bolts (37), hex head, 1/2-13 x 2.25 in., stainless steel
- 12 washers (9), stainless steel

Stainless Steel with Polypropylene Air Section Kit includes:

- 12 bolts (36 and 37), hex head, 1/2-13 x 2.5 in., stainless steel
- 20 washers (9), stainless steel
- 8 nuts, hex, 1/2 in., stainless steel

Air Section

Sample Configuration Number							
Pump Size	Fluid Section	Air Section	Seats	Balls	Diaphragms	Connections	Options
VA80(HE)	A	A	SS	TF	NO	TN	00

-  Apply lithium-based grease.
-  Lips must face out of housing.
-  Torque to 41-54 Nm (30-40 ft-lb.).
-  Torque to 2.3-2.8 Nm (20-25 in.-lb.).

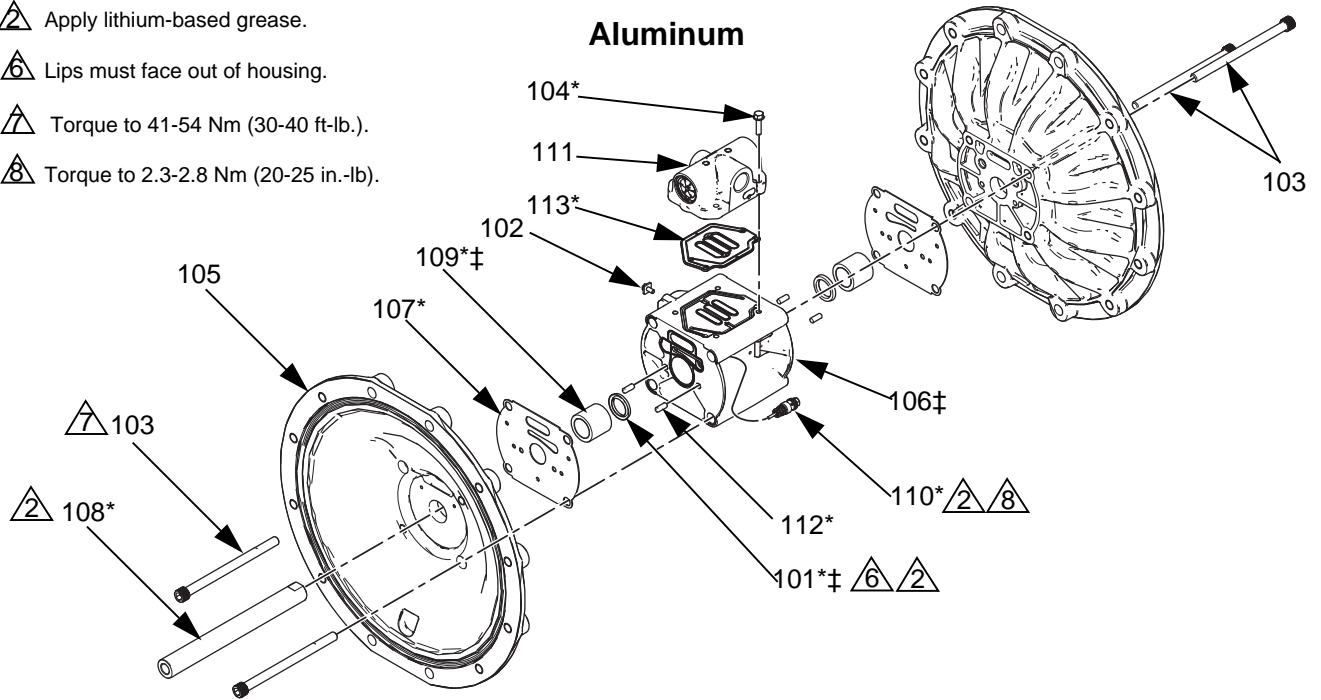

ti17768a

Aluminum Air Section

Ref.	Description	Qty.
101*‡	U-CUP, center shaft	2
102	SCREW, ground	4
103	BOLT, socket head, 7/16-14 x 6.25, zinc-plated carbon steel	4
104*	SCREW, M6 x 25, stainless steel	4
105	COVER, air	2
106‡	HOUSING, center	1
107*	GASKET, air cover	2
108*	SHAFT, center	1
109*‡	BEARING, shaft	2
110*	VALVE, pilot, assembly	2

Ref.	Description	Qty.
111	VALVE, air, see page 33	1
112*	PIN, dowel, stainless steel	4
113*	GASKET, air valve	1
114	LUBRICANT, thread, not shown	1
115	SEALANT, anaerobic, not shown	1

* Included in Air Section Rebuild Kit.

‡ Included in Center Housing Kit.

Sample Configuration Number							
Pump Size	Fluid Section	Air Section	Seats	Balls	Diaphragms	Connections	Options
VA80(HE)	A	A	SS	TF	NO	TN	00

Apply lithium-based grease.

Lips must face out of housing.

Torque to 34-47 Nm (25-35 ft.-lb.).

Torque to 2.3-2.8 Nm (20-25 in.-lb.).

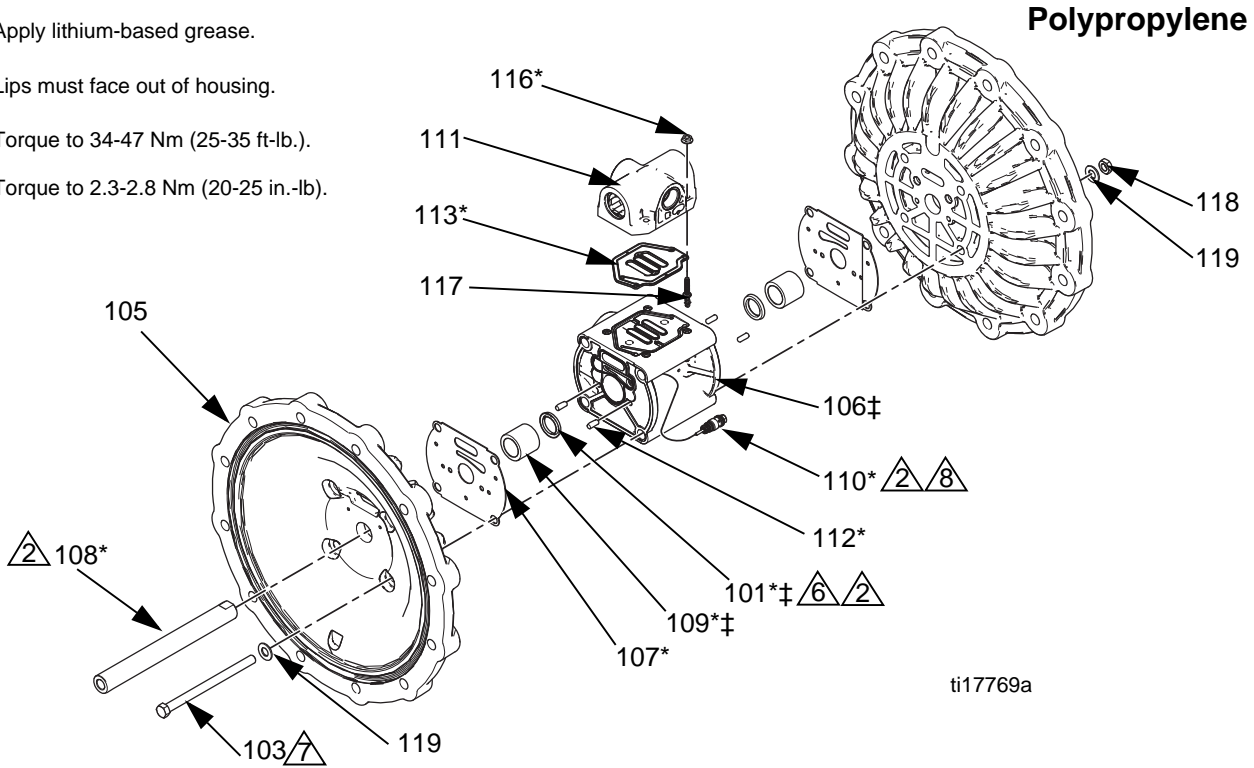

Polypropylene Air Section

Ref.	Description	Qty.
101*‡	U-CUP, center shaft	2
103	BOLT, hex head, 7/16-14 x 6.25, stainless steel	4
105	COVER, air	2
106‡	HOUSING, center	1
107*	GASKET, air cover	2
108*	SHAFT, center	1
109*‡	BEARING, shaft	2
110*	VALVE, pilot, assembly	2

Ref.	Description	Qty.
111	VALVE, air, see page 33	1
112*	PIN, dowel, stainless steel	4
113*	GASKET, air valve	1
114	LUBRICANT, thread, not shown	1
116*	NUT, serrated	4
117	SCREW, hi-lo stud	4
118	NUT, jam, 7/16, stainless steel	4
119	WASHER, 7/16, stainless steel	8

* Included in Air Section Rebuild Kit.

‡ Included in Center Housing Kit.

Sample Configuration Number							
Pump Size	Fluid Section	Air Section	Seats	Balls	Diaphragms	Connections	Options
VA80(HE)	A	A	SS	TF	NO	TN	00

Air Section Rebuild Kits (*)	
Pumps with standard diaphragms	859.0150
Pumps with overmolded diaphragms	859.0151

Kits include:

- 2 center shaft u-cups (101)
- 4 screws (104), M6 x 25, for [aluminum air section](#)
- 2 air cover gaskets (107)
- 1 center shaft (108)
- 2 center shaft bearings (109)
- 2 pilot valve assemblies (110)
- 4 dowel pins (112)
- 1 air valve gasket (113)
- 4 nuts (116), serrated, for [polypropylene air section](#)
- 1 grease packet

Pilot Valve Assembly Kits	
All Models	859.0116

Kits include:

- 2 pilot valve assemblies (110)

Center Shaft Kits	
Pumps with standard diaphragms	859.0152
Pumps with overmolded diaphragms	859.0153

Kit includes:

- 2 center shaft u-cups (101)
- 1 center shaft (108)
- 2 center shaft bearings (109)

Center Shaft Bearing Kits	
All Models	859.0154

Kit includes:

- 2 center shaft u-cups (101)
- 2 center shaft bearings (109)

Air Cover Kits	
Aluminum	859.0167
Polypropylene	859.0168

Kits include:

- 1 air cover (105)
- 1 air cover gasket (107)
- 2 dowel pins (112)

Air Cover Center Bolt Kits	
Aluminum Air Section	859.0169
Polypropylene Air Section	859.0170

Aluminum Kit includes:

- 4 bolts (103), 7/16-14 x 6.25 in.

Polypropylene Kit includes:

- 4 bolts (103), 7/16-14 x 6.25 in.
- 4 jam nuts (118)
- 8 washers (119)

Center Housing Kits (‡)	
Aluminum	859.0405
Polypropylene	859.0406

Kit includes:

- 2 center shaft bearings (109)
- 2 center shaft u-cups (101)
- 1 center housing (106)

Air Valve

Sample Configuration Number							
Pump Size	Fluid Section	Air Section	Seats	Balls	Diaphragms	Connections	Options
VA80(HE)	A	A	SS	TF	NO	TN	00

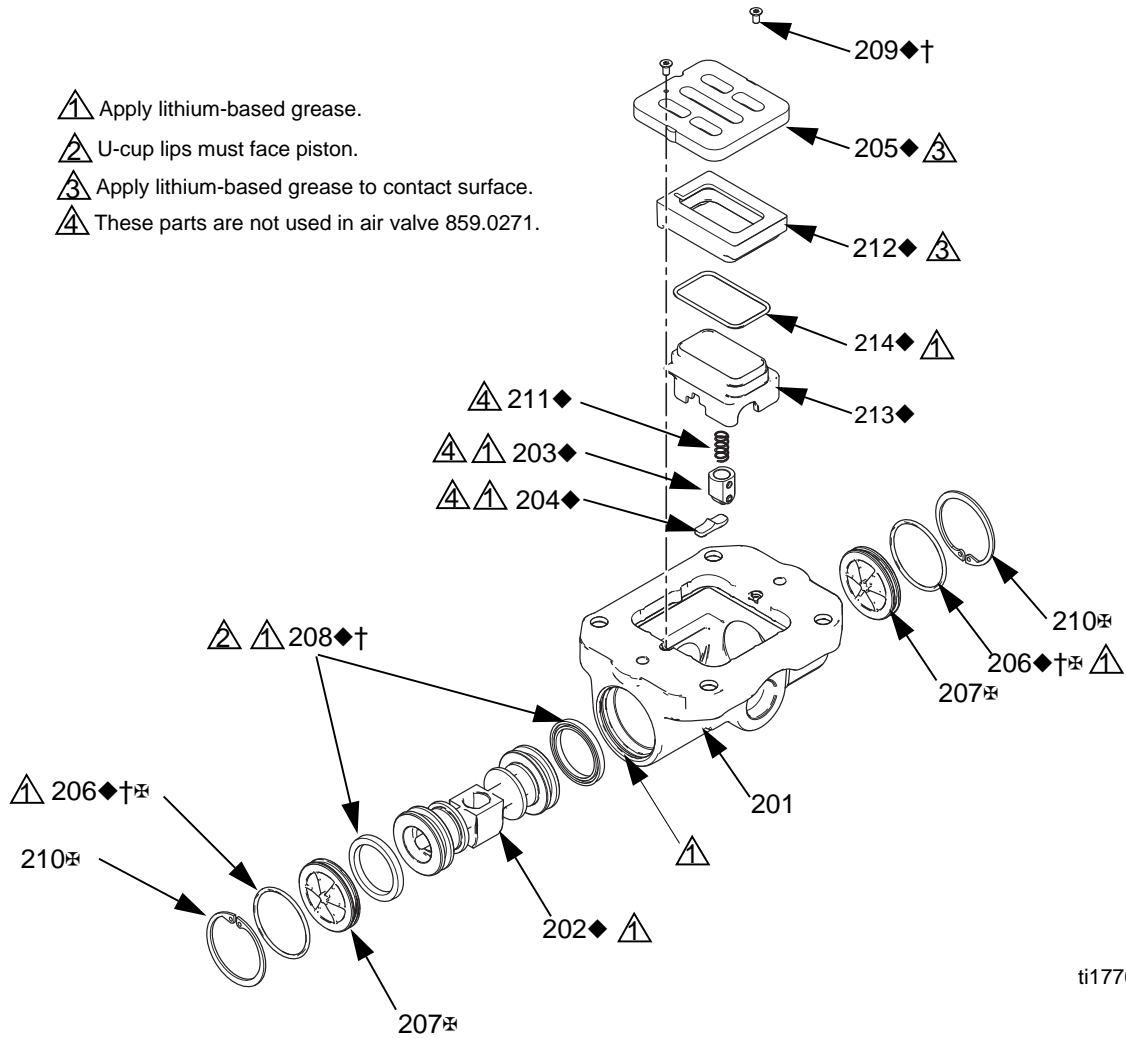

ti17765a

Ref.	Description	Qty.
201	HOUSING, not sold separately	1
202♦	PISTON	1
203♦	DETENT PISTON ASSEMBLY	1
204♦	CAM, detent	1
205♦	PLATE, air valve	1
206♦†‡	O-RING	2
207‡	CAP, end	2
208♦†	U-CUP	2
209♦†	SCREW	2
210‡	RETAINING RING	2
211♦	DETENT SPRING	1

Ref.	Description	Qty.
212♦	BASE, cup	1
213♦	CUP	1
214♦	O-RING, cup	1

♦ Parts included in Air Valve Repair Kit. See page 33.
 † Parts included in Air Valve Seals Kit. See page 33.
 ‡ Parts included in Air Valve End Cap Kit. See page 33.

Sample Configuration Number							
Pump Size	Fluid Section	Air Section	Seats	Balls	Diaphragms	Connections	Options
VA80(HE)	A	A	SS	TF	NO	TN	00

Air Valve Seal Kits (†)	
All Models	859.0159

Kit includes:

- 2 end cap o-rings (206)
- 2 piston u-cups (208)
- 2 screws, M3, shorter (209, for metal pumps)
- 2 screws, #4, longer (209, for plastic pumps)
- 1 air valve gasket (113)
- 1 grease packet
- 1 solenoid release button o-ring (not shown, not used)

Air Valve Repair Kits (◆)	
All Models	859.0160

Kits include:

- 1 air valve piston (202)
- 1 detent piston assembly (203)
- 1 detent cam (204)
- 1 air valve plate (205)
- 2 end cap o-rings (206)
- 2 piston u-cups (208)
- 2 screws, M3, shorter (209, for metal pumps)
- 2 screws, #4, longer (209, for plastic pumps)
- 1 detent spring (211)
- 1 air cup base (212)
- 1 air cup (213)
- 1 air cup o-ring (214)
- 1 solenoid release button o-ring (not shown, not used)
- 1 air valve gasket (113)
- 1 grease packet

Air Valve Replacement Kits	
Aluminum	859.0155
Polypropylene	859.0157
Polypropylene (TO only)	859.0271

Kits include:

- 1 air valve assembly (1b)
 - 1 air valve gasket (113)
 - 4 screws (109; models with aluminum centers)
- OR**
- 4 nuts (112; models with plastic centers)

Air Valve End Cap Kits (⊕)	
Aluminum	859.0103
Polypropylene	859.0073

Kits include:

- 2 end caps (207)
- 2 retaining rings (210)
- 2 o-rings (206)

Pulse Count Kits	
Aluminum	859.0052
Polypropylene	859.0051

For use with customer-supplied fluid management or inventory tracking systems. Kits include:

- 1 reed switch assembly
- 1 mounting screw

Seats and Check Balls

Sample Configuration Number							
Pump Size	Fluid Section	Air Section	Seats	Balls	Diaphragms	Connections	Options
VA80(HE)	A	A	SS	TF	NO	TN	00

NOTE: Some kits may not be available for your model. See the configurator tool at www.verderair.com or speak with your distributor.

NOTE: Some kits may not be available for your model. See the configurator tool at www.verderair.com or speak with your distributor.

Seat Kits	
AC*	859.0212
AL*	859.0213
BN	859.0214
VT	859.0220
GE*	859.0215
PP*	859.0217
SP*	859.0218
SS*	859.0219
HY	859.0216

Kits include:

- 4 seats (10), material indicated in table

* These seats require o-rings, which are sold separately.

Seat O-Ring Kits	
BN	859.0209
VT	859.0210
TF	859.0211

Kit Includes:

- 8 o-rings (13)

Check Ball Kits	
AC	859.0221
BN	859.0222
VT	859.0229
GE	859.0223
NE	859.0225
NW	859.0226
TF	859.0227
SP	859.0228
HY	859.0224

Kits Include:

- 4 balls (11), material indicated in table

Diaphragms

Sample Configuration Number							
Pump Size	Fluid Section	Air Section	Seats	Balls	Diaphragms	Connections	Options
VA80(HE)	A	A	SS	TF	NO	TN	00

NOTE: Some kits may not be available for your model. See the configurator tool at www.verderair.com or speak with your distributor.

Standard Diaphragm Kits	
BN	859.0197
NE	859.0204
VT	859.0203
GE	859.0200
SP	859.0202
HY	859.0201

Kits include:

- 2 diaphragms (20, material indicated in table)
- 2 o-rings (17) for the bolt (used only on metal pumps)
- 1 diaphragm install tool (302), not included with rubber diaphragms

NOTE: Diaphragm plates (14, 15), washer (18) and diaphragm shaft bolts (16) are sold in separate kits. See page 37. The shaft (108) is part of Kit 859.0150, the Air Section Rebuild Kit.

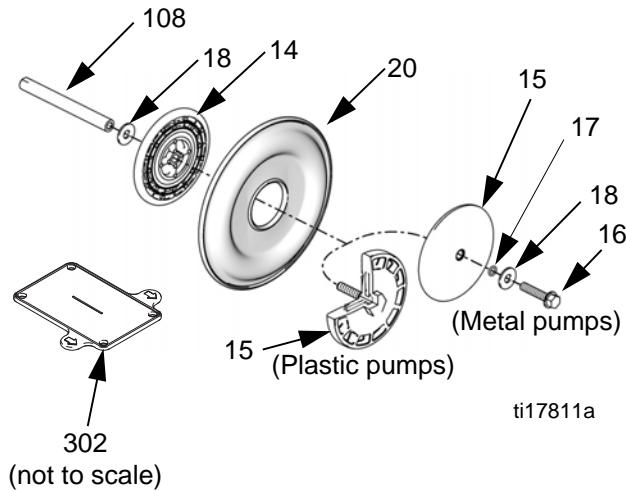

Overmolded Diaphragm Kits	
NO	859.0198
TO	859.0199

Kits include:

- 2 overmolded diaphragms (20, material indicated in table)
- 2 diaphragm set screws, stainless steel (16)
- 1 diaphragm install tool (302)
- 1 Loctite packet

NOTE: Air plates (14) and washer (18) are sold in a separate kit. See page 37. The shaft (108) is part of Kit 859.0151, the Air Section Rebuild Kit.

NOTE: Air Valve Replacement Kit 859.0271 is recommended for use with PTFE Overmolded diaphragm for maximum diaphragm life. See **Air Valve Replacement Kits**, page 33.

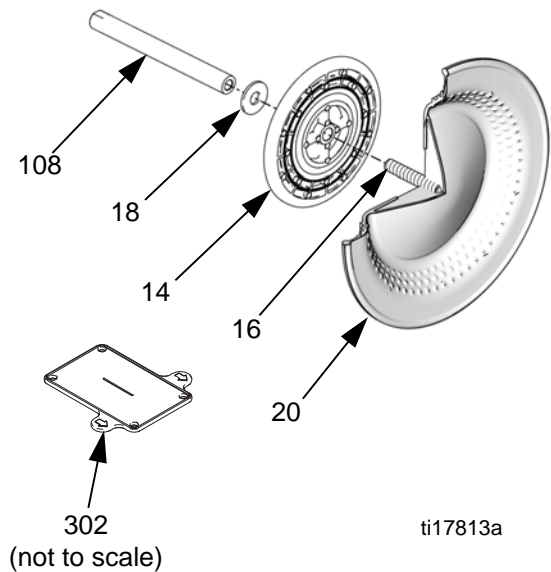

Diaphragms (continued)

Sample Configuration Number							
Pump Size	Fluid Section	Air Section	Seats	Balls	Diaphragms	Connections	Options
VA80(HE)	A	A	SS	TF	NO	TN	00

Two-Piece Diaphragm Kits	
TF	859.0205

Kits include:

- 2 diaphragms (20), PTFE
- 2 backup diaphragms (305), Santoprene
- 2 o-rings for the bolt (17, used only on metal pumps)
- 1 diaphragm install tool (302)

NOTE: Diaphragm plates (14, 15), washer (18) and diaphragm shaft bolts (16) are sold in a separate kit. See page 37. The shaft (108) is part of Kit 859.0150, the Air Section Rebuild Kit.

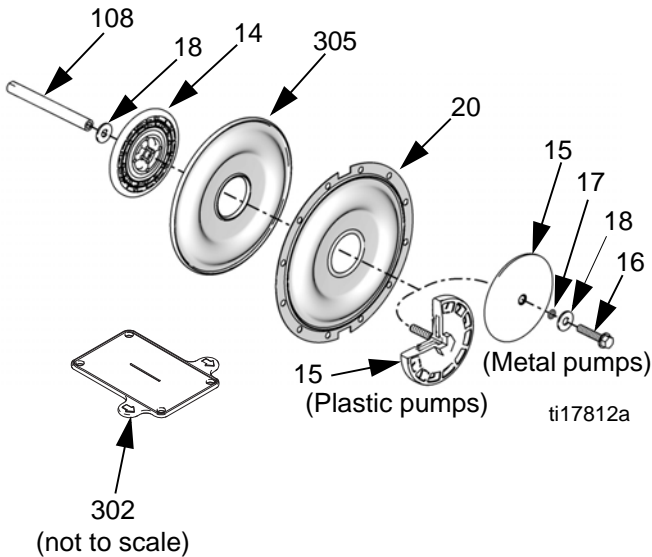

Fluid Plate Kits	
Aluminum	859.0206
Polypropylene	859.0207
Stainless Steel	859.0208

Kits for **aluminum** and **stainless steel** pumps include:

- 1 fluid side diaphragm plate (15)
- 1 washer (18)
- 1 o-ring (17)
- 1 bolt (16)

Kits for **polypropylene** pumps include:

- 1 air side diaphragm plate (14)
- 1 fluid side diaphragm plate (15)
- 1 washer (18)

Air Plate Kits	
All Models	859.0235

Kits include:

- 1 air side diaphragm plate (14)
- 1 washer (18)
- 1 o-ring (17)

Mounting Bracket Kits	
Aluminum	859.0234
Polypropylene and Stainless Steel	859.0233

Kit Includes:

- 2 mounting brackets (23)
- 4 bolts (24)
- 4 nuts (22), aluminum pumps **OR**
- 4 nuts (10) and 8 washers (9), polypropylene or stainless steel pumps

Accessories

Grounding Wire Assembly Kit 819.0157

Includes ground wire and clamp.

Muffler 819.6591

Legacy or remote exhaust muffler option.

Seat, Check Ball, and Diaphragm Kits

Sample Configuration Number							
Pump Size	Fluid Section	Air Section	Seats	Balls	Diaphragms	Connections	Options
VA80(HE)	A	A	SS	TF	NO	TN	00

Kit	Description	Qty.
859.0197	VA80(HE)M/P --,--BN,TF	1
859.0198	VA80(HE)M/P --,--,NO,--	1
859.0199	VA80(HE)M/P --,--,TO,--	1
859.0200	VA80(HE)M/P --,--,GE,TF	1
859.0201	VA80(HE)M/P --,--,HY,TF	1
859.0202	VA80(HE)M/P --,--,SP,TF	1
859.0203	VA80(HE)M/P --,--,VT,TF	1
859.0204	VA80(HE)M/P --,--,NE,TF	1
859.0205	VA80(HE)M/P --,--,TF,TF	1
859.0209	VA80(HE)M/P --,--,--BN	1
859.0210	VA80(HE)M/P --,--,--VT	1
859.0211	VA80(HE)M/P --,--,--TF	1
859.0212	VA80(HE)M/P AC,--,--,--	1
859.0213	VA80(HE)M/P AL,--,--,--	1
859.0214	VA80(HE)M/P BN,--,--,--	1
859.0215	VA80(HE)M/P GE,--,--,--	1
859.0216	VA80(HE)M/P HY,--,--,--	1
859.0217	VA80(HE)M/P PP,--,--,--	1
859.0218	VA80(HE)M/P SP,--,--,--	1
859.0219	VA80(HE)M/P SS,--,--,--	1
859.0220	VA80(HE)M/P VT,--,--,--	1
859.0221	VA80(HE)M/P --,AC,--,--	1
859.0222	VA80(HE)M/P --,BN,--,--	1
859.0223	VA80(HE)M/P --,GE,--,--	1
859.0224	VA80(HE)M/P --,HY,--,--	1
859.0225	VA80(HE)M/P --,NE,--,--	1
859.0226	VA80(HE)M/P --,NW,--,--	1
859.0227	VA80(HE)M/P --,TF,--,--	1
859.0228	VA80(HE)M/P --,SP,--,--	1
859.0229	VA80(HE)M/P --,VT,--,--	1
859.0745	VA80(HE)M/P SS,TF,TF,--	1
859.0419	VA80(HE)M/P GE,GE,GE,--	1
859.0420	VA80(HE)M/P AL,GE,GE,--	1
859.0421	VA80(HE)M/P AL,BN.BN,--	1
859.0422	VA80(HE)M/P SS,SP,SP,--	1
859.0423	VA80(HE)M/P PP,TF,TF,--	1
859.0424	VA80(HE)M/P SP,SP,SP,--	1
859.0425	VA80(HE)M/P SS,NW,NO,--	1
859.0426	VA80(HE)M/P AL,SP,SP,--	1

Kit	Description	Qty.
859.0427	VA80(HE)M/P AL,TF,TF,--	1
859.0532	VA80(HE)M/P BN,BN,BN,--	1
859.0600	VA80(HE)M/P SS,SP,SP,TF	1
859.0601	VA80(HE)M/P SS,BN,BN,TF	1
859.0602	VA80(HE)M/P BN,NW,BN,TF	1

Technical Data

Verderair VA 80 (HE)		
	US	Metric
Maximum fluid working pressure		
Aluminum or Stainless Steel with Aluminum Air Section	125 psi	0.86 MPa, 8.6 bar
Polypropylene or Stainless Steel with Polypropylene Air Section	100 psi	0.7 MPa, 7 bar
Air pressure operating range**		
Aluminum or Stainless Steel with Aluminum Air Section	20-125 psi	0.14-0.86 MPa, 1.4-8.6 bar
Polypropylene or Stainless Steel with Polypropylene Air Section	20-100 psi	0.14-0.7 MPa, 1.4-7 bar
Air consumption		
All pumps	90 scfm at 70 psi, 100 gpm	2.5 m ³ /min at 4.8 bar, 379 lpm
Maximum air consumption*		
Aluminum or Stainless Steel with Aluminum Air Section	335 scfm	9.5 m ³ /min
Polypropylene or Stainless Steel with Polypropylene Air Section	275 scfm	7.8 m ³ /min
Maximum free-flow delivery*		
Standard diaphragms	300 gpm at 125 psi	1135 lpm at 8.6 bar
Standard diaphragms	280 gpm at 100 psi	1059 lpm at 7 bar
Overmolded diaphragms	270 gpm at 125 psi	1022 lpm at 8.6 bar
Overmolded diaphragms	260 gpm at 100 psi	984 lpm at 7 bar
Maximum Pump Speed*		
Standard diaphragms	103 cpm at 125 psi	103 cpm at 8.6 bar
Standard diaphragms	97 cpm at 100 psi	97 cpm at 7 bar
Overmolded diaphragms	135 cpm at 125 psi	135 cpm at 8.6 bar
Overmolded diaphragms	130 cpm at 100 psi	130 cpm at 7 bar
Maximum suction lift (varies widely based on ball/seat selection and wear, operating speed, material properties, and other variables)*		
Dry	16 ft.	4.9 meters
Wet	31 ft.	9.4 meters
Recommended cycle rate	35-50 cpm	
Maximum size pumpable solids	1/2 in.	13 mm
Fluid flow per cycle**		
Standard diaphragms	2.9 gal	11.0 l
Overmolded diaphragms	2.0 gal	7.6 l
Ambient Temperature		
Minimum ambient air temperature for operation and storage. NOTE: Exposure to extreme low temperatures may result in damage to plastic parts.	32° F	0° C

Verderair VA 80 (HE)		
	US	Metric
Noise (dBa)**		
Sound Power	99.1 at 50 psi and 50 cpm, 106.1 at 125 psi and full flow	99.1 at 3.4 bar and 50 cpm 106.1 at 8.6 bar and full flow
Sound Pressure	91.5 at 50 psi and 50 cpm 98.2 at 125 psi and full flow	91.5 at 3.4 bar and 50 cpm 98.2 at 8.6 bar and full flow
Inlet/Outlet Sizes		
Fluid inlet - Polypropylene	3 in. ANSI/DIN flange, 8 bolts	
Fluid inlet - Aluminum	3 in.-8 npt or 3 in.-11 bspt with 3 in. ANSI/DIN flange	
Fluid inlet - Stainless Steel	3 in.-8 npt or 3 in.-11 bspt	
Air Inlet - all pumps	3/4 in. npt(f)	
Wetted parts		
All pumps	Materials chosen for seat, ball, and diaphragm options, plus the pump's material of construction - aluminum, polypropylene, or stainless steel. Aluminum pumps also have carbon-coated steel.	
Non-wetted external parts		
Polypropylene	stainless steel, polypropylene	
Aluminum	aluminum, coated carbon steel	
Stainless Steel	stainless steel, polypropylene or aluminum (as used in the air section)	
Weight		
Polypropylene	200 lb	91 kg
Aluminum	150 lb	68 kg
Stainless Steel	255 lb	116 kg
Notes		
* <i>Maximum values with water as media at ambient temperature. Water level is approximately 3 feet above pump inlet.</i>		
** <i>Startup pressures and displacement per cycle may vary based on suction condition, discharge head, air pressure, and fluid type.</i>		
*** <i>Sound power measured per ISO-9614-2. Sound pressure was tested 3.28 ft (1 m) from equipment.</i>		
Santoprene® is a registered trademark of the Monsanto Co.		
Loctite® is a registered trademark of the Loctite Corporation.		

Fluid Temperature Range

NOTICE

Temperature limits are based on mechanical stress only. Certain chemicals will further limit the fluid operating temperature range. Stay within the temperature range of the most-restricted wetted component. Operating at a fluid temperature that is too high or too low for the components of your pump may cause equipment damage.

Diaphragm/Ball/Seat Material	Fluid Temperature Range			
	Aluminum Pumps		Polypropylene Pumps	
Acetal	10° to 180°F	-12° to 82°C	32° to 150°F	0° to 66°C
Buna-N	10° to 180°F	-12° to 82°C	32° to 150°F	0° to 66°C
FKM Fluoroelastomer*	-40° to 275°F	-40° to 135°C	32° to 150°F	0° to 66°C
Geolast®	-40° to 150°F	-40° to 66°C	32° to 150°F	0° to 66°C
Polychloroprene overmolded diaphragm or Polychloroprene check balls	0° to 180°F	-18° to 82°C	32° to 150°F	0° to 66°C
Polypropylene	32° to 150°F	0° to 66°C	32° to 150°F	0° to 66°C
PTFE overmolded diaphragm	40° to 180°F	4° to 82°C	40° to 150°F	4° to 66°C
PTFE check balls	40° to 220°F	4° to 104°C	40° to 150°F	4° to 66°C
Santoprene® or two-piece PTFE/Santoprene diaphragm	-40° to 180°F	-40° to 82°C	32° to 150°F	0° to 66°C
TPE	-20° to 150°F	-29° to 66°C	32° to 150°F	0° to 66°C

* The maximum temperature listed is based on the ATEX standard for T4 temperature classification. If you are operating in a non-explosive environment, FKM fluoroelastomer's maximum fluid temperature in aluminum pumps is 320°F (160°C).

Customer Services/Guarantee

CUSTOMER SERVICES

If you require spare parts, please contact your local distributor, providing the following details:

- Pump Model
- Type
- Serial Number, and
- Date of First Order.

GUARANTEE

All VERDER pumps are warranted to the original user against defects in workmanship or materials under normal use (rental use excluded) for two years after purchase date. This warranty does not cover failure of parts or components due to normal wear, damage or failure which in the judgement of VERDER arises from misuse.

Parts determined by VERDER to be defective in material or workmanship will be repaired or replaced.

LIMITATION OF LIABILITY

To the extent allowable under applicable law, VERDER's liability for consequential damages is expressly disclaimed. VERDER's liability in all events is limited and shall not exceed the purchase price.

WARRANTY DISCLAIMER

VERDER has made an effort to illustrate and describe the products in the enclosed brochure accurately; however, such illustrations and descriptions are for the sole purpose of identification and do not express or imply a warranty that the products are merchantable, or fit for a particular purpose, or that the products will necessarily conform to the illustration or descriptions.

PRODUCT SUITABILITY

Many regions, states and localities have codes and regulations governing the sale, construction, installation and/or use of products for certain purposes, which may vary from those in neighboring areas. While VERDER attempts to assure that its products comply with such codes, it cannot guarantee compliance, and cannot be responsible for how the product is installed or used. Before purchasing and using a product, please review the product application as well as the national and local codes and regulations, and be sure that product, installation, and use complies with them.

Original instructions. This manual contains English.
Revision T, December 2019

Austria

Verder Austria
Eitnergasse 21/Top 8
A-1230 Wien
AUSTRIA
Tel: +43 1 86 51 074 0
Fax: +43 1 86 51 076
e-mail: office@verder.at

Belgium

Verder nv
Kontichsesteenweg 17
B-2630 Aartselaar
BELGIUM
Tel: +32 3 877 11 12
Fax: +32 3 877 05 75
e-mail: info@verder.be

China

Verder Shanghai Instruments and Equipment Co., Ltd
Building 8 Fuhai Business Park No. 299
Bisheng Road, Zhangjiang Hiteck Park
Shanghai 201204
CHINA
Tel: +86 21 33932950
Fax: +86 21 33932955
e-mail: info@verder.cn

Bulgaria

Verder Bulgaria Ltd
Vitosh department,
Manastriski Livadi Zapad
district,
110 Bulgaria Blvd., 2-nd
Floor, apt. 15-16,
1618 - Sofia
BULGARIA
Tel: 0878407370
Fax: 02 9584085
email: office@verder.bg

Czech Republic

Verder s.r.o.
Vodnanská 651/6 (vchod
Chlumecka 15)
198 00 Praha 9-Kyje
CZECH REPUBLIC
Tel: +420 261 225 386-7
Web: <http://www.verder.cz>
e-mail: info@verder.cz

France

Verder France
8 Allée Rosa Luxembourg
Immeulde Arizona
95610 Eragny sur Oise
FRANCE
Tel: +33 173 43 98 41
Fax: +33 134 64 44 50
e-mail: info@verder.fr

Germany

Verder Deutschland GmbH
Retsch-Allee 1-5
42781 Haan
GERMANY
Tel: 02104/2333-200
Fax: 02104/2333-299
e-mail: info@verder.de

Hungary

Verder Hungary Kft
Budafoke ut 187 - 189
HU-1117 Budapest
HUNGARY
Tel: 0036 1 3651140
Fax: 0036 1 3725232
e-mail: info@verder.hu

India

Verder India Pumps Pvt
Ltd.
Plot No-3B, D-1 Block,
MIDC Chinchwad,
Pune - 411019
INDIA
e-mail:
Sales@verder.co.in
www.verder.co.in

Italy

Verder Italia
Via Maestri Del lavoro, 5
02100 Vazia, Rieti
ITALY
Tel: +39 07 46 229064
e-mail: info@verder.it

The Netherlands

Verder BV
Leningradweg 5
NL 9723 TP Groningen
THE NETHERLANDS
Tel: +31 50 549 59 00
Fax: +31 50 549 59 01
e-mail: info@verder.nl

Poland

Verder Polska
ul.Porcelanowa 23
PL-40 036 Katowice
POLAND
Tel: +48 32 78 15 032
Fax: +48 32 78 15 034
e-mail: verder@verder.pl

Romania

Verder România
Drumul Balta Doamnei
no 57-61
Sector 3
CP 72-117
032624 Bucuresti
ROMANIA
Tel: +40 21 335 45 92
Fax: +40 21 337 33 92
e-mail: office@verder.ro

Slovak Republik

Verder Slovakia s.r.o.
Silacska 1
SK-831 02 Bratislava
SLOVAK REPUBLIK
Tel: +421 2 4463 07 88
Fax: +421 2 4445 65 78
e-mail: info@verder.sk

South Africa

Verder SA
197 Flaming Rock Avenue
Northlands Business Park
Newmarket Street
ZA Northriding
SOUTH AFRICA
Tel: +27 11 704 7500
Fax: +27 11 704 7515
e-mail: info@verder.co.za

Switzerland

Verder Deutschland GmbH
Sales Switzerland
Retsch-Allee 1-5
D-42781 Haan
GERMANY
Tel: +41 (0)61 331 33 13
Fax: +41 (0)61 331 63 22
e-mail: info@verder.ch

United Kingdom

Verder UK Ltd.
Unit 3 California Drive
Castleford, WF10 5QH
UNITED KINGDOM
Tel: +44 (0) 1924 221 001
Fax: +44 (0) 1132 465 649
e-mail: info@verder.co.uk

United States of America

Verder Inc.
312 Corporate Parkway
Suite 101
Macon, GA 31210
USA
Tel: +1 877 783 7337
Fax: +1 478 476 9867
e-mail: sales@verder-us.com